



GSW WATER HEATING
 599 Hill Street West
 Fergus, ON, Canada N1M 2X1



INDIRECT WATER HEATER INSTALLATION AND OPERATING INSTRUCTIONS

Read and understand these instructions thoroughly before starting

TABLE OF CONTENTS

I) Introduction2
 II) Safety2
 III) Installation2
 IV) Operation4
 V) Maintenance4
 Warranty6

PLEASE RETAIN THESE INSTRUCTIONS IN A SAFE LOCATION FOR FUTURE REFERENCE



⚠ WARNING:

Improper installation, adjustment, alteration, service, or maintenance can cause injury or property damage. Refer to this manual. For assistance or additional information, consult a qualified installer, service agency, or the electric utility.

⚠ FOR YOUR SAFETY

- Do not store or use gasoline or other flammable vapours and liquids in the vicinity of this or any other appliance.
- Installation and service must be performed by a qualified installer, service agency or the electric utility.

⚠ WARNING:

If the information in these instructions is not followed exactly, a fire or explosion may result causing property damage, personal injury or death.

⚠ CAUTION:

The heat transfer medium must be water or other nontoxic fluid having a toxicity rating or class of 1, as listed in Clinical Toxicology of Commercial Products, 5th edition.

The pressure of the heat transfer medium must be limited to a maximum of 30 PSIG by an approved safety or relief valve.

IF YOU HAVE ANY INSTALLATION, PERFORMANCE OR OPERATIONAL QUESTIONS PLEASE CALL THE FOLLOWING NUMBER, PRIOR TO REMOVING THE WATER HEATER

(if this is a rental water heater please contact the rental company)

**1-888-GSW-TECH
 1-888-479-8324**

I) INTRODUCTION

Thank you for purchasing this water heater. Properly installed and maintained, it will provide years of trouble free service.

The warranty on this water heater is in effect only when the water heater is installed and operated in accordance with these instructions. The manufacturer of this water heater will not be liable for any injury or property damage resulting from failure to comply with these instructions.

IMPORTANT:

This water heater must be installed strictly in accordance with the instructions enclosed, and local electrical, fuel and building codes. It is possible that connections to the water heater, or the water heater itself, may develop leaks. IT IS THEREFORE IMPERATIVE that the water heater be installed so that any leakage of the tank or related water piping is directed to an adequate drain in such a manner that it cannot damage the building, furniture, floor covering, adjacent areas, lower floors of the structure or other property subject to water damage. This is particularly important if the water heater is installed in a multi-story building, on finished flooring or carpeted surfaces. GSW WILL NOT ASSUME ANY LIABILITY for damage caused by water leaking from the water heater, pressure relief valve, or related fittings. Select a location as centralized within the piping system as possible. In any location selected, it is recommended that a suitable drain pan be installed under the water heater. This pan must limit the water level to a MAXIMUM depth of 45mm (1 3/4 in.) and have a diameter that is a minimum of 50mm (2 in.) greater than the diameter of the water heater. Suitable piping shall connect the drain pan to a properly operating floor drain. When used with a fuel-fired heater, this drain pan must not restrict combustion air flow.

Closets without drains and carpeted areas are examples of unsuitable locations for any water heater. If this heater is to be installed directly on carpeting, the carpeting must be protected by a metal or wood panel beneath the heater, extending beyond the full width and depth of the heater by a minimum 80mm (3 in.). If the heater is installed in a closet or alcove, the entire floor must be covered by the panel. This panel must be strong enough to support the weight of the

CAUTION

Hydrogen gas can be produced in a hot water system served by this heater that has not been used for a long period of time (generally two (2) weeks or more). **Hydrogen gas is extremely flammable and can ignite when exposed to a spark or flame.** To reduce the risk of injury under these conditions, it is recommended that the hot water faucet be opened for several minutes at the kitchen sink before using any electrical appliance connected to the hot water system. Use caution in opening faucets. If hydrogen is present, there will probably be an unusual sound such as air escaping through the pipe as the water begins to flow. There should be no smoking or open flame near the faucet at the time it is open.

heater full of water without breaking. Failure to heed this warning may result in a fire hazard.

II) SAFETY

Relief Valve Requirements

Caution: To reduce the risk of excessive pressures and temperatures in this water heater, install temperature and pressure protective equipment required by local codes. It should be no less than a combination temperature and pressure relief valve certified by a nationally recognized testing laboratory that maintains periodic inspection of production of listed equipment or materials, as meeting the latest edition of **ANSI Z21.22: Requirements for Relief Valves and Automatic Gas Shut-off Devices for Hot Water Supply Systems.** This valve must be marked with a maximum set pressure not to exceed the marked MAXIMUM working pressure of the water heater (150 PSI). Install the valve into an opening provided and marked for this purpose in the water heater, and orient it or provide tubing so that any discharge from the valve will exit only within 6 inches above, or at any distance below the structural floor and cannot contact any live electrical part. The discharge opening must not be blocked or reduced in size under any circumstances. The end of the relief pipe opening should terminate near a floor drain or other suitable location not subject to blocking or freezing. DO NOT thread, plug or cap the relief pipe opening.

III) INSTALLATION

WARNING

If the output of the energy source is more than 100,000 btu/h, the installed temperature-pressure relief valve should be replaced with a temperature-pressure relief valve having a rated capacity that is equal to or greater than the output of the energy source.

Removal of the installed (or failure to replace) listed 3/4" temperature-pressure relief valve will release the manufacturer from any claim which might result from excessive temperatures and pressures.

INSTALLATION RECORD

This water heater is protected by a multi-year warranty against leaks plus a one (1) year warranty on parts. Record key data here for future reference and prompt service:

Installed By / Purchased From:		
Installation Date:	Location of Electrical Switch or Circuit Protector:	
Model Number	Serial Number	
Watts	Watts	Watts-Total
Volts	P.S.I.	U.S. Gal.

PLEASE REFER TO BOILER MANUFACTURER INSTRUCTIONS FOR PLUMBING CONNECTION GUIDELINES.

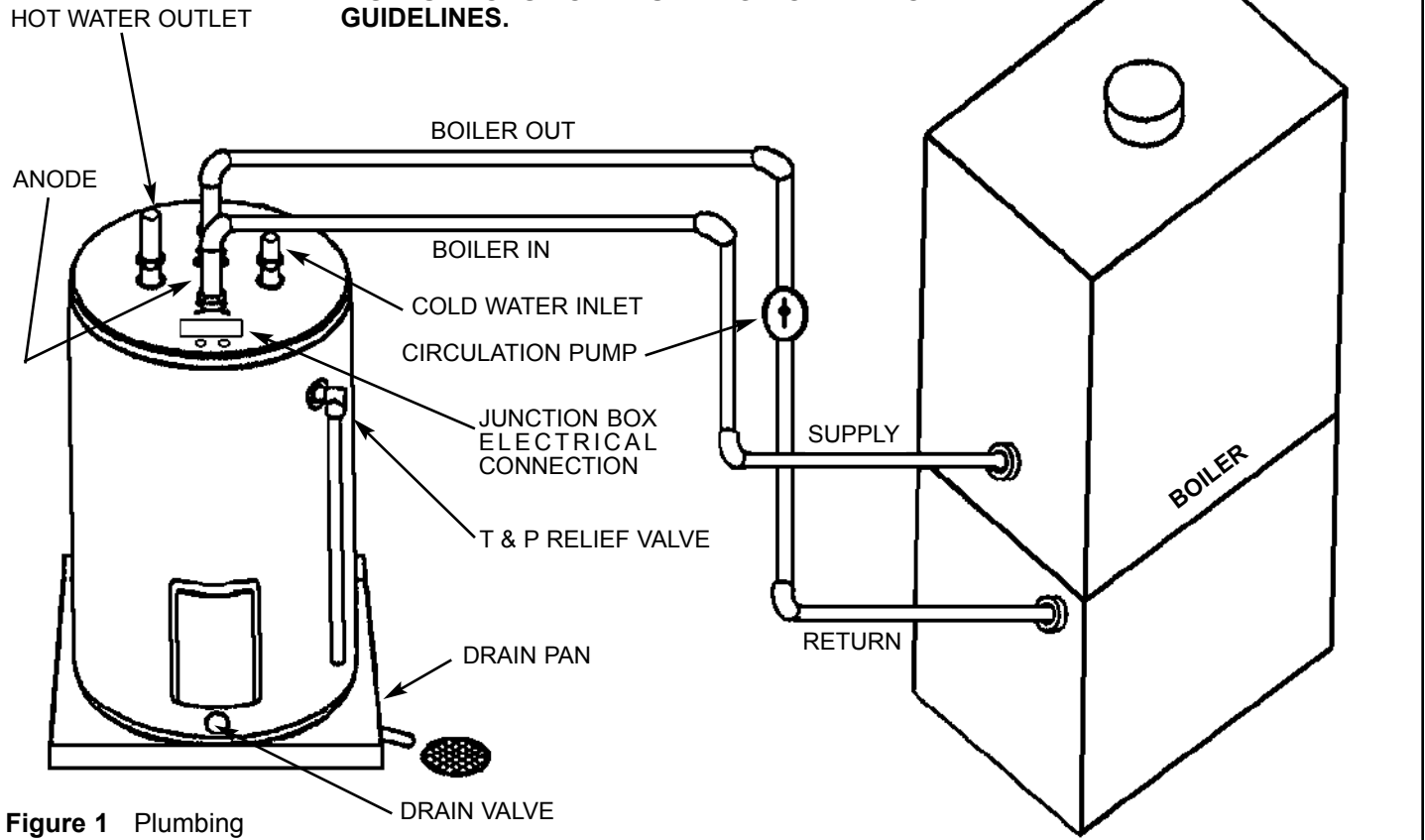

Figure 1 Plumbing

Location

1. Do not locate the heater where water lines could be subjected to freezing temperatures.
2. It is desirable to have a floor drain nearby to permit easy draining if necessary.
3. The drain valve and all access panels must be accessible for maintenance and service.
4. Install the water heater so that if there is a leak, the resulting flow of water will not cause damage to the area adjoining the water heater. Under no condition is the manufacturer liable for any water damage in connection with this water heater.

Plumbing

1. Ensure the heater is level before starting the installation.
2. Install a shut-off valve in the cold water line. This is for emergency shut-off. It must be kept open during the heater's operation.
3. A certified relief valve must be installed as shown in Figure 1.

DO NOT OPERATE THE HEATER WITHOUT A RELIEF VALVE - SEE NOTE ON RELIEF VALVE.

4. When using copper piping, solder a piece of tubing to a threaded adaptor before screwing the adaptor to the tank. Do not apply heat directly to inlet or outlet connections.
5. Install a drip tube from the relief valve terminating at sink or drain.

DO NOT CAP OR THREAD THE END OF A DRIP TUBE - IT MUST BE UNOBSTRUCTED AND FULL SIZE.

6. The two threaded pipe nipples which are supplied with the heater should be attached to the "Boiler In" and "Boiler Out" connections. Connect the "Boiler In" fitting of the heater to the "supply" fitting of the Boiler and "Boiler Out" fitting of the heater to "return" fitting of the Boiler. A suitable circulator pump should be placed between "Boiler Out" at the heater and "Return" at the water heater. See Figure 1.

Wiring

1. Remove Access cover on top of the heater.
2. Connect wiring to circulator pump as shown in Figure 2. A No. 14 AWG Type TEW 105°C wire was installed in this heater. If wire has to be replaced in the field, use only type TEW 105°C wire.
3. A ground wire must be run from the ground screw at the heater junction box to the ground connection at the service panel.
4. The maximum inductive rating of this circuit is 7.2 F.L.A 120 VAC. Do not exceed this rating.
5. Ensure that wiring conforms to local codes.

Filling

To fill the heater:

1. Open a hot water faucet.
2. Open the cold water supply valve.
3. When water runs out of the hot faucet the tank is filled.
4. Check the system for leaks.

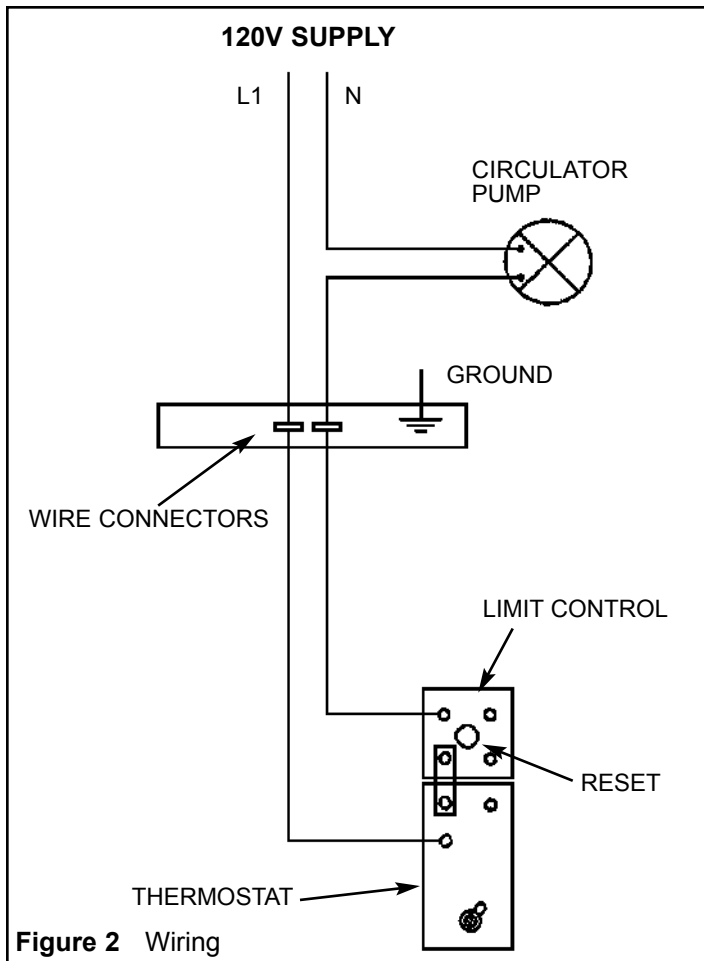

- To fill the coil of the heater to be used in conjunction with the boiler, refer to Boiler instructions.

NOTE: WHEN FILLING, AVOID WATER SPILLAGE. DO NOT ALLOW THE INSULATION OF THE HEATER TO GET WET AS WATER CAN CAUSE ELECTRICAL MALFUNCTION.

IV) OPERATION

Temperature Adjustment

CAUTION

INCREASING THE THERMOSTAT SETTING ABOVE THE PRE-SET TEMPERATURE MAY CAUSE SEVERE BURNS AND CONSUME EXCESSIVE ENERGY. HOTTER WATER INCREASES THE RISK OF SCALD INJURY.

In order to reduce the risk of scald injury, thermostats are factory set at 50°C (120°F). The thermostats operate automatically. They can be adjusted to provide warmer or cooler water temperature. The setting of 50°C (120°F) has been proven to most satisfactory from the standpoint of operational costs and safety. We recommend the thermostats remain set at 50°C (120°F).

If water temperature adjustment is required:

- Turn off the electrical supply.
- Remove the access door.
- Turn back insulation.
- Adjust the thermostat to the water temperature desired.

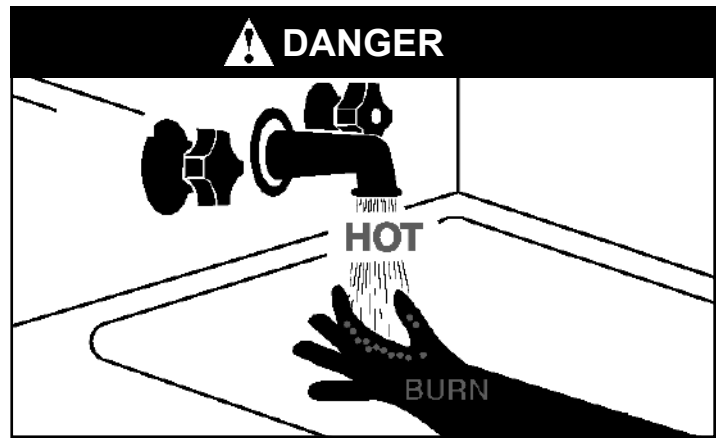

- Replace insulation and access door.
- Turn on electrical supply.

Temperature Limit Control

For safety, a non-adjustable high limit temperature switch will shut off the power when excessive water temperatures are reached. This switch must be re-set manually.

V) MAINTENANCE

Establish a maintenance program to extend the life of your water heater. Most water heater failures are due to lime/sediment buildup, excessive pressure or corrosion.

To Reduce Lime/Sediment Buildup (Every 6 months):

- Turn off the electrical supply to the water heater.
 - Close the cold water inlet valve.
 - Open a nearby hot water faucet.
 - Connect a hose to the drain valve and terminate it to an adequate drain.
- Note:** The drain hose should be rated for at least 93°C (200°F). If the drain hose does not have this rating, open the cold water inlet valve and a nearby hot faucet until the water is no longer hot. Close the cold water inlet valve.
- Open the water heater drain valve and allow all the water to drain from the tank.
 - When the tank is empty and the water flow stops, close the drain valve.
 - Remove the anode rod.
 - Pour 3 or 4 gallons of "apple" cider vinegar into "anode bolt" hole and re-insert anode rod. Use Teflon® tape or approved pipe sealant on the threads.
 - Let the vinegar sit in the tank for 24 to 36 hours.
 - Open the drain valve.
 - Open the cold water inlet valve and let water flow from the drain hose for 5 minutes.
- Note:** If water does not flow freely from the drain hose, check the hose for (and remove) blockages (e.g. lime scale pieces).
- Close the drain valve and remove the hose.
 - Ensure a hot water faucet is open (to vent the system).
 - Fill tank and close the hot water faucet when a steady flow of water with no air bubbles appears (6 minutes).
 - Turn on the electrical supply to the water heater.

To Assure Relief Valve Operation (Every 12 months):

Manually open the relief valve to flush any lime deposits that may have developed. **CAUTION! Water can be extremely hot.** Make certain the seat closes properly. Let it snap shut. See Figure 3.

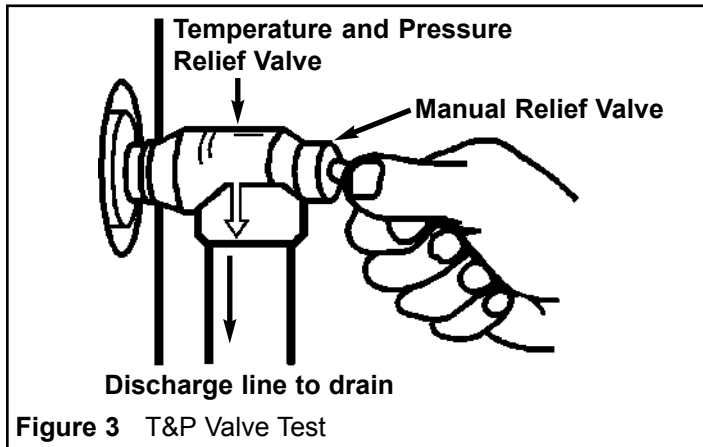

Figure 3 T&P Valve Test

Cathodic Protection

Your water heater has been equipped with an anode that protects the tank from corrosion. As the anode works, it slowly dissolves over time and may need to be replaced. If the anode is less than 10mm (3/8 in.) in diameter, or has any exposed bare core, it must be replaced. Depending on water conditions, an anode can last from one to ten years. Many localities treat their water, which can have significant effect on the life of your heater. Water conditioning, such as over-softening, can accelerate the rate at which the anode is consumed. Rapid depletion can leave a heater unprotected causing a premature failure. As with any water heater, it is good practice to check the anode annually to see if it needs replacing. Operating a water heater without an actively working anode will void the warranty. Failure to maintain the anode may result in premature failure of the heater.

To Prevent Corrosion Of The Tank (Every 12 months):

1. Turn the electrical supply to the water heater "OFF".
2. Close the cold inlet supply valve.
3. Open a hot water tap supplied by the heater. (**CAUTION: Water will be hot.**)
4. Remove enough water to empty the piping system.
5. Using a 1 1/16" socket remove anode, inspect and replace if required. The anode is centrally located in the top of the heater.
6. To refill the heater, see 'Filling' section.

Pressure Build-Up In A Water System

During the heating cycle of the water heater the water expands, creating a pressure build-up in the water system. The water supply meter may contain a check valve or back-flow preventer. This will create a closed water system. A temperature and pressure relief valve must be installed on the water heater (150 PSI maximum pressure setting, see temperature and pressure relief valve.) To prevent this "T & P VALVE" from discharging hot water, the loss of energy and to reduce the possible build-up of lime in the "T & P VALVE" there are two recommendations:

1. Install an expansion tank on the cold water supply line. For every 50 U.S. gallons of stored water the expansion tank must have a minimum capacity of 1.5 U.S. gallons.
- or**
2. Install a 125 PSI Pressure relief (only) valve in the cold water supply line. Make sure that the discharge of this valve is directed to a drain to prevent water damage and ensure that it is protected from freezing.

WARNING: Failure of the internal heating coil could cause an over pressurization of heating system boiler and a discharge of water from the boiler pressure relief valve.

LIMITED WARRANTY

See Rating Label Serial Number prefix for
Warranty Code.

Warranty Code: P R S T U V W Y
Warranty Years: 3 5 6 7 8 9 10 12

RESIDENTIAL STORAGE TANK TYPE WATER HEATER FOR INSTALLATION IN A SINGLE FAMILY DWELLING

A. WHO IS COVERED.

GSW WATER HEATING AND ITS SUPPLIERS, (herein collectively referred to as "Manufacturer") warrants only to the original consumer purchaser (hereinafter "Owner") of the water heater, within the boundaries of continental United States, or Canada, or their territories, so long as he or she continuously occupies the single family dwelling in which this water heater is initially installed for the period specified below. This warranty is not transferable. This warranty is reduced to one year if the water heater is used in a commercial, or industrial application, or if the water heater is used to supply more than one dwelling unit. Consumers must retain point-of-sale proof of purchase to validate warranty entitlement.

B. WHEN IT IS COVERED.

The water heater is warranted only when it is installed, operated and maintained in accordance with the printed instructions accompanying the water heater. The water heater shall/must be installed in such a manner that, if the tank or any connection thereto should leak, the resulting flow of water will not cause damage to the area in which it is installed. The water heater's temperature and pressure relief valve must be piped to the nearest drain to avoid damage in the event the valve is actuated. For detailed instructions read the manual accompanying the water heater and review drawings in the manual.

C. WHAT THE MANUFACTURER WILL DO AND THE PERIOD OF COVERAGE.

1. **The Inner Tank.** If the inner tank leaks within the warranty period shown in the table at the top of this page after the original installation, Manufacturer will furnish a new water heater of Manufacturer's then prevailing comparable model. If industry standards, regulatory changes, product improvements or product obsolescence prohibits Manufacturer from furnishing an identical model replacement water heater under this warranty, the Owner will be furnished with a new water heater of comparable capacity; however, the Owner will be charged for the additional value of the item(s) which Manufacturer has incorporated in the replacement water heater. A prior authorization number must be obtained from the Manufacturer before replacing the water heater. This warranty is limited to one replacement water heater at the original installation site.
2. **Component Part.** If any component part other than the inner tank proves to Manufacturer's satisfaction to be defective in material or workmanship within one (1) year, the Manufacturer will furnish the Owner with a replacement for the defective part(s). This warranty is limited to one replacement component part for each original part.
3. **Return of Defective Water Heater and Component Parts.** Manufacturer reserves the right to examine the alleged defect in the water heater or component part(s), and it will be the Owner's obligation (See paragraph D.5) to return the water heater and/or component part(s) to the Manufacturer.
 - a. When returning a water heater it must include all component parts and the data plate label.
 - b. When returning component part(s), they must be individually tagged and identified with the water heater's product number, model number, serial number, date of purchase and date of installation.
 - c. THERE ARE NO WARRANTIES WHICH EXTEND BEYOND THE DESCRIPTION ON THE FACE HEREOF. THIS EXPRESS WARRANTY IS, WHERE PERMITTED BY LAW, IN LIEU OF AND EXCLUDES AND REPLACES ALL OTHER CONDITIONS, WARRANTIES, GUARANTEES, REPRESENTATIONS, OBLIGATIONS OR LIABILITIES OF THE MANUFACTURER OF ANY NATURE OR KIND, EXPRESS OR IMPLIED, HOWEVER ARISING (WHETHER BY CONTRACT, CONDUCT, STATEMENT, STATUTE, NEGLIGENCE, PRINCIPLES OF MANUFACTURER'S LIABILITY, OPERATION OF LAW OR OTHERWISE) WITH RESPECT TO THE UNIT OR ITS FITNESS FOR A PARTICULAR PURPOSE, MERCHANTABILITY, INSTALLATION, OPERATION, REPAIR OR REPLACEMENT. THE MANUFACTURER EXPRESSLY DISCLAIMS ANY AND ALL IMPLIED WARRANTIES. IN NO EVENT WILL THE MANUFACTURER'S LIABILITIES EXCEED THE COST OF THE DEFECTIVE PART(S) OR UNIT.

D. WHAT THIS WARRANTY DOES NOT COVER.

1. The Unit must not be installed where water damage can result from a leak, while provision(s) shall be made for directing any water escaping from the Unit, to a properly operating drainpipe. As all units of this type may eventually leak, you must protect against any potential water damage. The Manufacturer accepts no responsibility for such damage, nor any incidental or consequential loss, nor damage(s) related thereto, suffered by the Owner of the Unit nor by any third party.
2. Manufacturer shall not be liable under this warranty and this warranty shall be void and have no effect if the following events occur:
 - a. The water heater or any of its component parts have been subject to misuse, alteration, neglect or accident; or
 - b. The water heater has not been installed in accordance with the applicable local plumbing and/or building code(s) and/or regulations or in their absence, with the latest edition of the Natural Gas and Propane Installation Code, and/or the Canadian Electrical Code; or
 - c. The water heater is not installed, operated and maintained in accordance with the Manufacturer's instructions; or

- d. The water heater or any of its component parts are damaged or fails from operation with an empty or partially empty tank (such as, but not limited to elements burned out in a dry tank); or
 - e. The water heater or any part has been under water; or
 - f. The water heater is exposed to highly corrosive atmospheric conditions. No warranty extends, for example, and without limitation of the foregoing, to Units exposed to: salts, chemicals, exhausts, pollutants or contaminants; or
 - g. The water heater is not continuously supplied with potable water; or
 - h. The water heater replacement is requested for reasons of noise, taste, odor, discoloration and/or rust; or
 - i. The water heater is operated at temperatures exceeding the maximum setting of the thermostat and/or high limit control provided by the Manufacturer, or at water pressures exceeding the pressure reading stated on the Unit; or
 - j. The water heater is operated without an operating anode; or
 - k. The water heater is supplied or operated with deionized water; or
 - l. The water heater is removed from its original installation location; or
 - m. The water heater is installed outdoors (this water heater is intended only for indoor installation); or
 - n. The water heater is converted, or is attempted to be converted, from one voltage or wattage to another, if an electric water heater, or from one type gas to another, if a gas water heater; or
 - o. The water heater has not been fired at the factory rated input and fuel for which it was factory built; or
 - p. The water heater or any of its component parts fail due to sediment build-up; or
 - q. The water heater does not have installed a properly operating temperature and pressure relief valve, certified to ANSI Z21.22/CSA "Requirements for Relief Valves for Hot Water Supply Systems"; or
 - r. The water heater or any of its component parts fail because of fire, floods, lightening, or any other act of God, or any other contingency beyond the control of the Manufacturer; or
 - s. The water heater is installed in a closed system without adequate provision for thermal expansion.
3. Except when specifically prohibited by the applicable law, the Owner, and not the Manufacturer, shall be liable for and shall pay for all charges for labour or other expenses incurred in the removal, repair or replacement of the water heater or any component part(s) claimed to be defective or any expense incurred to remedy any defect in the product. Such charges may include, but are not necessarily limited to:
 - a. All freight, shipping, handling and delivery costs of forwarding a new water heater or replacement part(s) to the Owner.
 - b. All costs necessary or incidental in removing the defective water heater or component part(s) and installing a new water heater or component part(s).
 - c. Any material required to complete, and/or permits required for, installation of a new water heater or replacement part(s), and
 - d. All costs necessary or incidental in returning the defective water heater or component part(s) to a location designated by the Manufacturer.
 4. The terms of this Limited Warranty cannot be modified by any person, whether or not he/she claims to represent or act on behalf of the Manufacturer.
- E. HOW THE ORIGINAL OWNER CAN MAKE A WARRANTY CLAIM.
1. The Owner should submit the warranty claim directly to Manufacturer's Service Department, at the address or phone number listed below, and Manufacturer will arrange for the handling of the claim.
 2. Whenever any inquiry or request is made, be sure to include the water heater's catalogue number, model number, serial number, date of purchase, date of installation, and location of installation.

This warranty and the Manufacturer's obligations shall be construed and determined in accordance with the laws of both the Province of Ontario, and of Canada in force therein. This Warranty does not affect specific legal rights of a consumer under applicable law, except to the extent that such rights may be waived or replaced, and the provisions hereof are deemed to be amended to the extent necessary. The unenforceability of any provision, in whole or in part, of this Certificate shall not affect the remaining provisions. Any and all repair and/or replacement of part(s) or Unit are the sole and exclusive remedy available against the Manufacturer.

GSW Water Heating
 599 Hill Street West
 Fergus, ON Canada N1M 2X1
 Should you have any questions please
 Email us at techsupport@gsw-wh.com or
 Visit our websites: www.gsw-wh.com or
www.johnwoodwaterheaters.com or
 Call our Technical Support line at
 1-888-GSW-TECH (479-8324)

This page intentionally left blank. May be used for notes or to record other installation information.