

Quiet, reliable and efficient operation in a quality design: the John Wood® Direct Vent water heater. The balanced flue design with a side wall vent termination allows installation in locations without a chimney. The sealed combustion chamber and co-axial vent uses fresh air taken from outside rather than pre-heated air from within the home. Ideal for applications where space is at a premium.

Features

Designed for Performance

- Thermopile design provides robust pilot to withstand down drafts and environmental conditions
- LED indicator:
 - Gives visual confirmation that pilot is on by flashing continuously
 - Provides diagnostics and troubleshooting
- Easy temperature adjustments
- Direct vent design means no external power supply or chimney required for operation/installation
- 90" coaxial vent supplied with water heater
- Top mounted heavy duty anode rod for added tank protection
- Glass-lined tank for longer life
- Factory-installed plastic-lined nipples with heat traps
- Automatic gas control
- CFC-free foam insulation
- 50 gallon high input model available for combination applications
- Suitable for closet installations
- 3/4" side taps available on 50 gallon high input model for combination applications

Safety Features

- Sealed combustion chamber design, eliminating the need for a Flammable Vapour sensor

Serviceability

- Combustion chamber is easy to access
- Conveniently located T&P and drain valve for ease of installation and serviceability

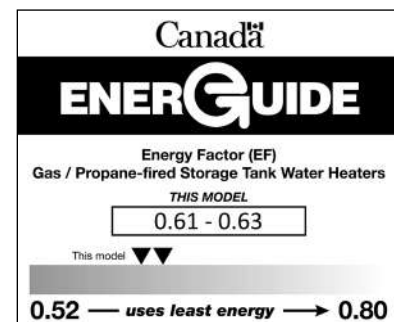

WARRANTY

8 Year Limited Tank Warranty

6 Year Limited Parts Warranty

Consult installation manual for terms and conditions or visit www.johnwoodwaterheaters.com for more information.

PERFORMANCE

Model	Series	Capacity		Maximum Certified Altitude	Recovery Rate at 90° F Temperature Rise	First Hour Rating	Energy Factor	BC Compliant
		USG(L)	BTU/h					
JW840S38N-DV	300/301	40 (151)	38,000	7,700 (2,347)	42 (159)	72 (273)	0.63	✓
JW850T40N-DV	300/301	50 (189)	40,000	7,700 (2,347)	43 (163)	91 (344)	0.62	✓
JW850T47N-DV*	300/301	50 (189)	47,000	7,700 (2,347)	51 (193)	92 (348)	0.61	✓

For propane models sub N with P. Natural gas models are series 300. Propane models are series 301.
*Model has side connections.

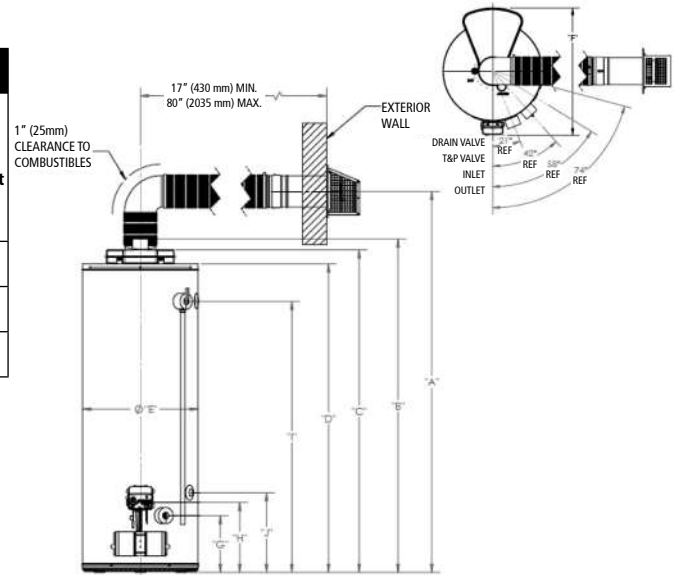

DIMENSIONS & SHIPPING WEIGHT

Model	Height to Center of Vent	Height to Top of Flue Outlet	Height to Top of Air Box	Height to Top of Heater	Diameter	Overall Depth	Height to Drain	Height to Gas Inlet	Height to T&P	Height to Side Tap (Hot Out)	Height to Side Tap (Cold In)	Shipping Weight
	A IN (CM)	B IN (CM)	C IN (CM)	D IN (CM)	E IN (CM)	F IN (CM)	G IN (CM)	H IN (CM)	I IN (CM)	I IN (CM)	J IN (CM)	LB (KG)
JW840S38N-DV	64 (163)	54 3/8 (138)	52 1/2 (133)	49 3/8 (126)	22 (56)	29 (74)	10 3/4 (27)	13 1/4 (34)	42 3/8 (108)	N/A	N/A	178 (81)
JW850T40N-DV	73 (185)	63 3/8 (162)	61 3/4 (157)	58 3/8 (150)	22 (56)	29 (74)	10 3/4 (27)	13 1/4 (34)	51 5/8 (131)	N/A	N/A	200 (91)
JW850T47N-DV*	74 (188)	64 3/8 (164)	62 7/8 (160)	60 (152)	22 (56)	29 (74)	10 3/4 (27)	13 1/4 (34)	52 3/4 (134)	52 3/4 (134)	15 1/4 (39)	215 (98)

PREFERRED INSTALLATION

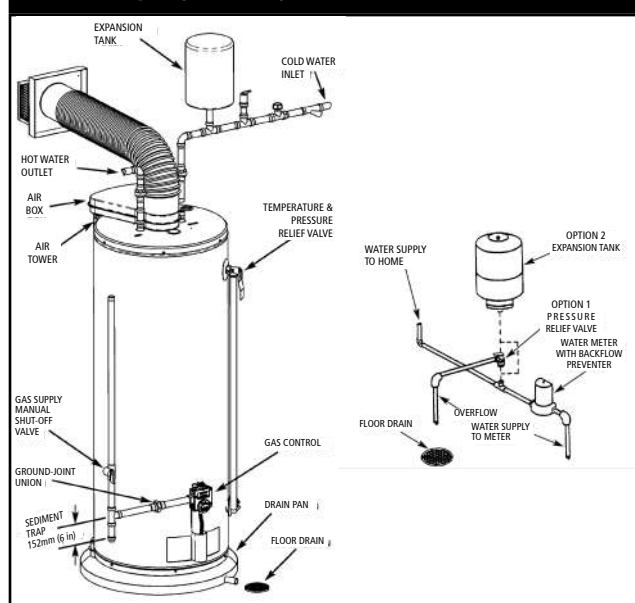

VENT LENGTHS

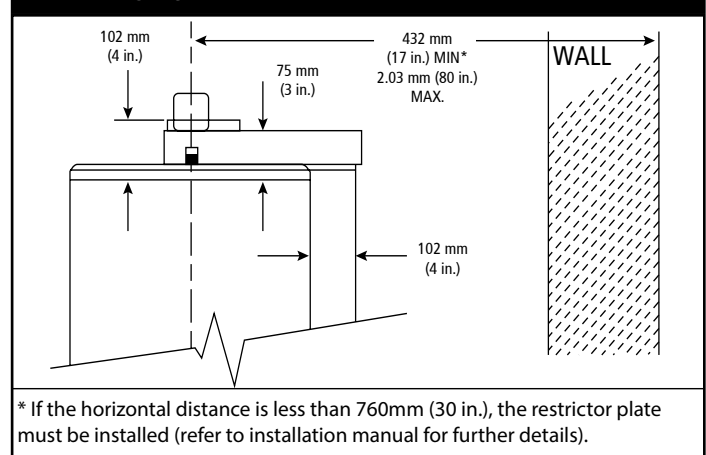

Refer to the installation manual for complete installation and venting requirements.