

John Wood ENERGY STAR[®] qualified Power Vent water heaters are engineered for increased efficiency and deliver dependable, trouble-free operation. The John Wood[®] Power Vent water heater design includes an advanced gas control with self-diagnostic capabilities for quick and easy servicing.

Features

Energy Savings

- ENERGY STAR[®] qualified
- Exceed NRCAN energy efficiency standards

Designed for Performance

- Compact design – ideal as a replacement water heater and for closet installations
- Exclusive TankSaver[®] design to prolong tank life
- Convenient 3/4" side water connections for combination applications on 62,000 BTU units

Safety Features

- Flammable vapour sensor detects the presence of flammable vapours and automatically disables the unit, preventing ignition
- Robust air intake snorkel inhibits flammable vapours from entering the sealed combustion chamber

Serviceability

- State-of-the-art gas control features advanced self-diagnostic capability that makes troubleshooting easy
- Conveniently located T&P and drain valve for ease of serviceability

The Ultimate in Venting Flexibility

- Can be vented with ULC s636 PVC, CPVC or polypropylene pipe



WARRANTY

8 Year Limited Tank Warranty

6 Year Limited Parts Warranty

Consult installation manual for terms and conditions or visit www.johnwoodwaterheaters.com for more information.

PERFORMANCE

Model	Capacity	Maximum Certified Altitude	Input	Recovery Rate at 100°F/55°C Temp. Rise	First Hour Rating	Energy Factor
	USG (L)	ft (m)	BTU/hr	USG/hr (L/hr)	USG (L)	
NATURAL GAS						
JW840NVH-ES2	40 (151)	4,500 (1,372)	42,000	39 (148)	69 (261)	0.67
JW850NVH-ES2	50 (189)	4,500 (1,372)	42,000	38 (144)	90 (341)	0.67
JW85065SNV-ES2*	50 (189)	4,500 (1,372)	62,000	57 (216)	110 (416)	0.67
JW860NVH-ES2	60 (227)	4,500 (1,372)	42,000	38 (144)	106 (401)	0.67
PROPANE						
6G40PVH-ES2-02	40 (151)	2,000 (610)	42,000	39 (148)	69 (261)	0.67
6G40PVH-ES2-04	40 (151)	4,500 (1,372)	42,000	39 (148)	69 (261)	0.67
6G50PVH-ES2-02	50 (189)	2,000 (610)	42,000	38 (144)	90 (341)	0.67
6G50PVH-ES2-04	50 (189)	4,500 (1,372)	42,000	38 (144)	90 (341)	0.67
6G5065SPV-ES2-02*	50 (189)	2,000 (610)	62,000	57 (216)	110 (416)	0.67
6G5065SPV-ES2-04*	50 (189)	4,500 (1,372)	62,000	57 (216)	110 (416)	0.67
6G60PVH-ES2-02	60 (227)	2,000 (610)	42,000	38 (144)	106 (401)	0.67
6G60PVH-ES2-04	60 (227)	4,500 (1,372)	42,000	38 (144)	106 (401)	0.67

* Model has side water connections

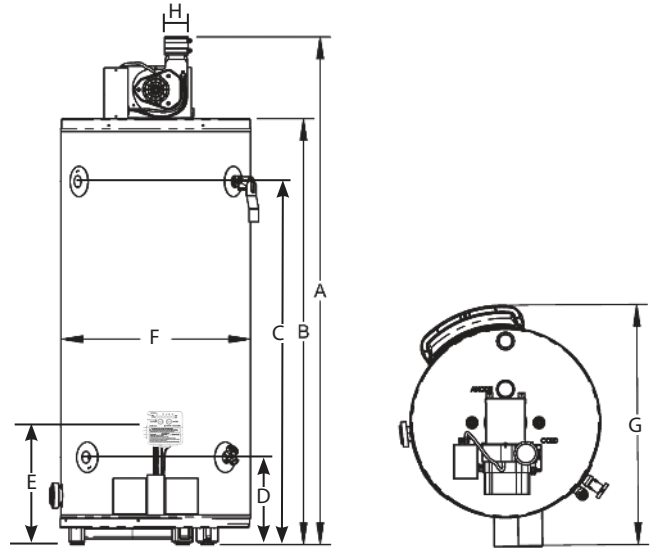
DIMENSIONS & SHIPPING WEIGHT

Model	Installation Height	Height to Top of Tank	Height to T&P and Upper Side Connection	Height to Drain Valve and Lower Side Connection	Height to Gas Inlet	Tank Diameter	Overall Depth	Vent Diameter	Approx. Shipping Weight
	A in (cm)	B in (cm)	C in (cm)	D in (cm)	E in (cm)	F in (cm)	G in (cm)	H in	lb (kg)
NATURAL GAS									
JW840NVH-ES2	58 ½ (149)	48 ½ (123)	41 ½ (105)	9 ½ (24)	13 ¼ (34)	21 ¼ (54)	27 (68)	2-3	190 (86)
JW850NVH-ES2	61 ¼ (156)	51 ¼ (130)	44 (112)	10 ½ (27)	14 ¾ (37)	22 ¾ (58)	28 ½ (72)	2-3	200 (90)
JW85065SNV-ES2	61 ¼ (156)	51 ½ (131)	44 ¼ (113)	10 ½ (27)	14 ¾ (37)	22 ¾ (58)	28 ½ (72)	3	200 (90)
JW860NVH-ES2	68 ½ (174)	58 ½ (149)	51 (130)	10 ½ (27)	14 ¾ (37)	22 ¾ (58)	28 ½ (72)	2-3	202 (91)
PROPANE									
6G40PVH-ES2	58 ½ (149)	48 ½ (123)	41 ½ (105)	9 ½ (24)	13 ¼ (34)	21 ¼ (54)	27 (68)	2-3	190 (86)
6G50PVH-ES2	61 ¼ (156)	51 ¼ (130)	44 (112)	10 ½ (27)	14 ¾ (37)	22 ¾ (58)	28 ½ (72)	2-3	200 (90)
6G5065SPV-ES2	61 ¼ (156)	51 ½ (131)	44 ¼ (113)	10 ½ (27)	14 ¾ (37)	22 ¾ (58)	28 ½ (72)	3	200 (90)
6G60PVH-ES2	68 ½ (174)	58 ½ (149)	51 (130)	10 ½ (27)	14 ¾ (37)	22 ¾ (58)	28 ½ (72)	2-3	202 (91)

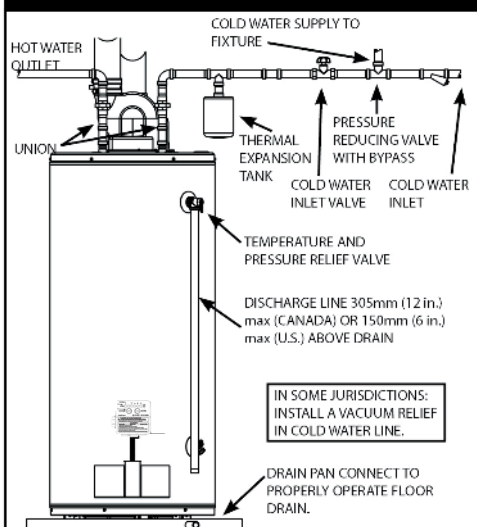
PREFERRED INSTALLATION

VENT PIPE LENGTHS

Model	Vent Pipe Diameter in	Minimum Number of Elbows Required*	Maximum Vent Length with 1 Elbow ft (m)	Minimum Vent Length with 1 Elbow ft (m)
JW840NVH-ES2 6G40PVH-ES2 JW850NVH-ES2	2	1	40 (12.3)	10.5 (3.2)
6G50PVH-ES2 JW860NVH-ES2 6G60PVH-ES2				
JW85065SNV-ES2 6G5065SPV-ES2	3	1	40 (12.3)	11 (3.4)

* Refer to installation manual for further details.