

INSTALLATION CONSIDERATIONS

- Noise – Vent terminal should be located away from bedroom windows or other areas where blower noise will be objectionable. Avoid venting into corners or confined areas, which will amplify sound. Anchoring intake or vent pipe to walls or ceilings can cause noise to be transmitted to living areas, and isolation mounts should be used where anchoring is required.
- Air Intake – In cold climates, air intake should be located at least four feet from the vent termination of the water heater and any other appliance vents that discharge moisture-laden air (such as clothes dryers). This will help prevent freeze-over of the intake screen required to prevent foreign objects from entering the intake pipe. Air intake should be located above the maximum snow line.
- Vent Termination – Exhaust gases of this water heater are less than 140°F (60°C). In cold climates water vapour in flue gases will condense into a cloud of vapour where the vent exits the building. This vapour can gradually discolor exterior building surfaces. Vent termination should be located where this vapour cloud and potential discoloration are not a concern. Extending the vent termination up to 6" from the wall helps vapour from being trapped along a building's face. To avoid this problem, the vent can be terminated on the roof. Always locate vent termination above the maximum snow line, and do not locate vent termination above a walkway.
- Condensate Drain – This is a fully condensing water heater and should be located near a drain to permit proper disposal of condensate.

Condensate Neutralizer Kits Available

CNS-2 Condensate Neutralizer Kit for 150 - 199k BTU Models	Part Number 9007959005
CNS-2 Refill Kit for 150 - 199k BTU Models	Part Number 9007964005
CNS-6 Condensate Neutralizer Kit for 250 - 400k BTU Models	Part Number 9007960005
CNS-6 Refill Kit for 250 - 400k BTU Models	Part Number 9007965005

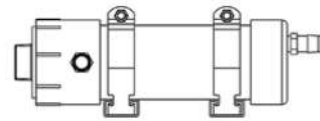

- Optional Concentric Vent Kit - Helps to minimize unsightly wall/roof penetrations.

Concentric Vent Kits Available

Concentric Vent Kit for 150 - 250k BTU Models	Part Number 9006328005
Concentric Vent Kit for 300 - 400k BTU Models	Part Number 9008841005



- Low Profile Termination Vent Kits Available

3" Flush Mount Vent Kit	Part Number 9008933005
4" Flush Mount Vent Kit	Part Number 9008934005
6" Flush Mount Vent Kit	Part Number 9008935005

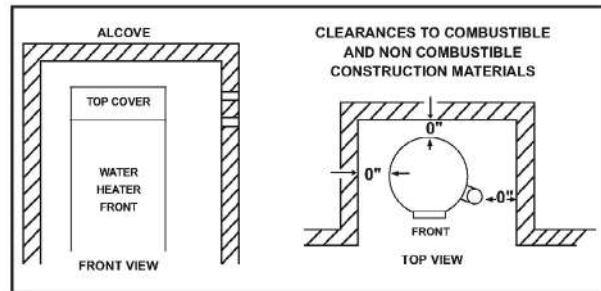
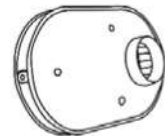

MINIMUM GAS LINE SIZE		
Model	Natural Gas	Propane
(A)JWSH100-150	3/4" N.P.T.	3/4" N.P.T.
(A)JWSH100-199	3/4" N.P.T.	3/4" N.P.T.
(A)JWSH100-250	3/4" N.P.T.	3/4" N.P.T.
AJWSH119-300	1 1/2" N.P.T.	1 1/2" N.P.T.
AJWSH119-400	1 1/2" N.P.T.	1 1/2" N.P.T.

MAXIMUM EQUIVALENT VENT LENGTHS (150 - 250K BTU)

*Number of 90° Elbows Installed	3 inch Pipe	4 inch Pipe
	Feet (Meters)	Feet (Meters)
One (1)	45 (14)	115 (35)
Two (2)	40 (12)	110 (34)
Three (3)	35 (11)	105 (32)
Four (4)	30 (9)	100 (31)
Five (5)	--	95 (29)
Six (6)	--	90 (27)

* Maximum number of 90° elbows allowed for the vent (exhaust) pipe is four (4) when installing 3 inch pipe and six (6) when installing 4 inch pipe. Maximum number of 90° elbows allowed for intake air pipe is four (4) when installing 3 inch pipe and six (6) when installing 4 inch pipe. Two (2) 45° elbows equal one (1) 90° elbow.

MAXIMUM EQUIVALENT VENT LENGTHS (300 - 400K BTU)

*Number of 90° Elbows Installed	4 inch Pipe	6 inch Pipe
	Feet (Meters)	Feet (Meters)
One (1)	65 (20)	115 (35)
Two (2)	60 (18)	110 (34)
Three (3)	55 (17)	105 (32)
Four (4)	50 (15)	100 (31)
Five (5)	45 (14)	95 (29)
Six (6)	40 (12)	90 (27)

* Maximum number of 90° elbows allowed for the vent (exhaust) pipe is six (6). Maximum number of 90° elbows allowed on the intake air pipe is six (6). Two (2) 45° elbows equal one (1) 90° elbow.

For Technical Information/Warranty:
Call 1-888-479-8324 or email techsupport@hotwater.com
www.johnwoodwaterheaters.com

ENERGY STAR® qualified John Wood® Commercial High Efficiency modulating gas water heaters feature a modulating burner that provides higher levels of efficiency. The unique helical coil heat exchanger limits weld joints for optimal service life while maximizing heat transfer.

Features

Energy Savings

- ENERGY STAR® qualified
- Rated thermal efficiencies up to 98% to lower operating costs
- Meets ASHRAE/IES 90.1 requirements

Designed for Performance

- Fully submerged, spiral-shaped condensing heat exchanger to maximize heat transfer, provide high efficiency, and avoid sediment buildup on the heat exchanger surface
- Down-fired pre-mix powered burner provides optimum efficiency and quiet operation
- Robust direct spark ignition for years of worry free operation
- Advanced control system provides detailed status information including diagnostics and run history information as well as precise temperature control adjustment from 90°F (32°C) to 180°F (82°C)
- Powered anodes: two titanium powered anodes provide superior tank protection in varying water conditions

Installation Flexibility

- Top mounted controls (gas valve, combustion, air blower) for easy access during installation and service
- 0" installation clearances on sides and rear, 1-1/2" installation clearance on top and 4" alcove installation clearance in front handhole cleanout of unit
- Zero clearance to combustibles enabling approval for installation on combustible flooring

Venting Flexibility

- Standard power vent or power direct vent flexibility, in vertical or sidewall configurations, using ULC S636 PVC, CPVC, polypropylene or AL29-4C stainless steel pipe in runs of up to 115 feet depending upon vent pipe size
- Optional vent termination kits are available - see back page for more information



(A)JWSH100-150—
(A)JWSH100-250



AJWSH119-300—
AJWSH119-400



WARRANTY

3 Year Limited Tank Warranty

1 Year Limited Parts Warranty

Consult installation manual for terms and conditions or visit www.johnwoodwaterheaters.com for more information.

OTHER FEATURES:

COMMERCIAL GRADE GLASS-LINED TANK AND HEAT EXCHANGER

- Heat exchanger glassed internally and externally to provide long term protection against corrosive flue gases and condensate

CODE COMPLIANCE

- The 150 - 250K BTU models are design-certified by CSA International, according to ANSI Z21.10.3 - CSA 4.3 standards governing storage-type water heaters
- The 300 & 400K BTU models are design-certified by Underwriter's Laboratories (UL), Inc., according to ANSI Z21.10.3 - CSA 4.3 standards governing storage-type water heaters
- Design-certified by Underwriter's Laboratories (UL), Inc. to NSF Standard for 180°F (82°C) water
- Meets or exceeds the thermal efficiency and standby loss requirements from current edition of ASHRAE/IESNA 90.1

HANDHOLE CLEANOUT

- For easy inspection and cleaning

THREE-YEAR LIMITED TANK WARRANTY

- For complete warranty information consult written warranty shipped with water heater or contact John Wood Water Heating

RECOVERY RATE GPH/LPH															
Model	Gas Type	Input Rate BTU/HR (kW)	Thermal Efficiency	Approx. Tank Capacity	Temperature Rise										
					30°F (17°C)	40°F (22°C)	50°F (28°C)	60°F (33°C)	70°F (39°C)	80°F (45°C)	90°F (50°C)	100°F (56°C)	110°F (61°C)	120°F (67°C)	130°F (72°C)
(A)JWSH100-150	NG/LP	150,000 (44)	98%	100 USG	576	432	345	288	247	216	192	173	157	144	133
				379 Litres	2179	1635	1308	1090	934	817	726	654	594	545	503
(A)JWSH100-199	NG/LP	199,900 (58)	97%	100 USG	767	575	460	384	329	288	256	230	209	192	177
				379 Litres	2904	2178	1743	1452	1245	1089	968	871	792	726	670
(A)JWSH100-250	NG/LP	250,000 (73)	96%	100 USG	960	720	576	480	411	360	320	288	262	240	221
				379 Litres	3632	2724	2179	1816	1557	1362	1211	1090	991	908	838
AJWSH119-300	NG/LP	300,000 (88)	96%	119 USG	1164	873	698	582	499	436	388	349	317	291	269
				450 Litres	4404	3303	2643	2202	1888	1652	1468	1322	1201	1101	1016
AJWSH119-400	NG/LP	399,900 (117)	95%	119 USG	1535	1151	921	767	658	576	512	460	419	384	354
				450 Litres	5810	4357	3486	2905	2490	2179	1937	1743	1585	1452	1341

Recovery capacities are based on heater performance at 95% to 98% thermal efficiencies. Add "A" in front of model number when ordering ASME. For example, AJWSH100-199N. N to P when ordering propane (LP). Maximum gas supply pressure for 150-400: 14" W.C. (3.49 kPa) for natural gas and propane. Manifold pressure: 0" W.C. (0 kPa) for natural gas and propane. Electrical requirements: 120 VAC/60Hz, Blower 2.2 Amps FL, Ignitor 4.0 Amps. AJWSH119-300 and 400 are available in ASME only.

(A)JWSH100-150 thru (A)JWSH100-250

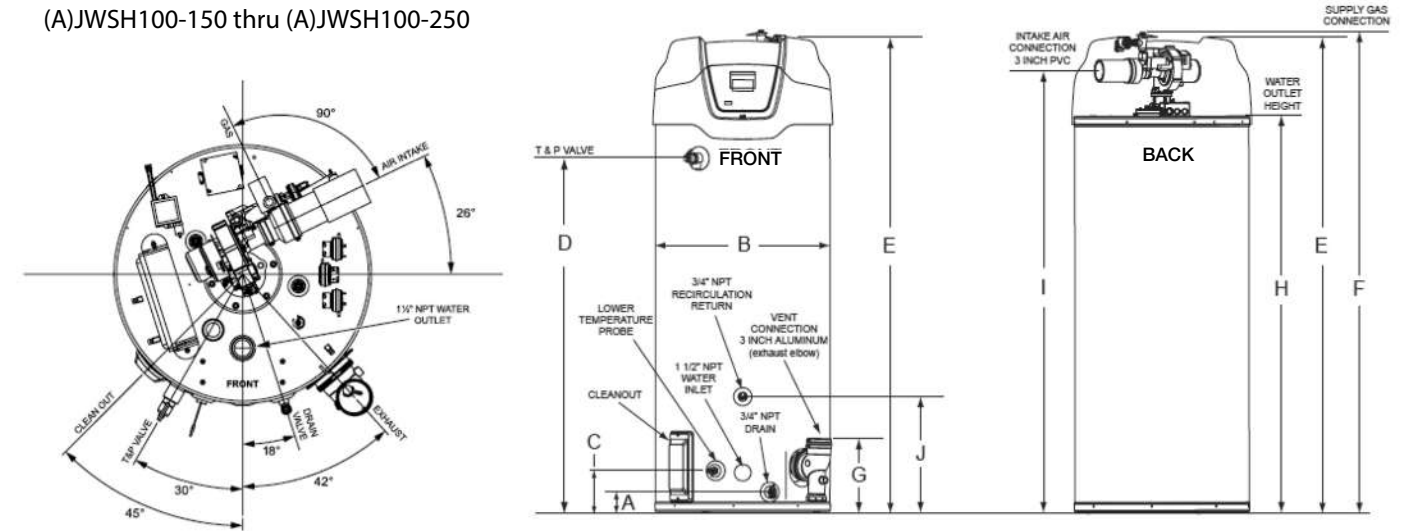

AJWSH119-300 thru AJWSH119-400

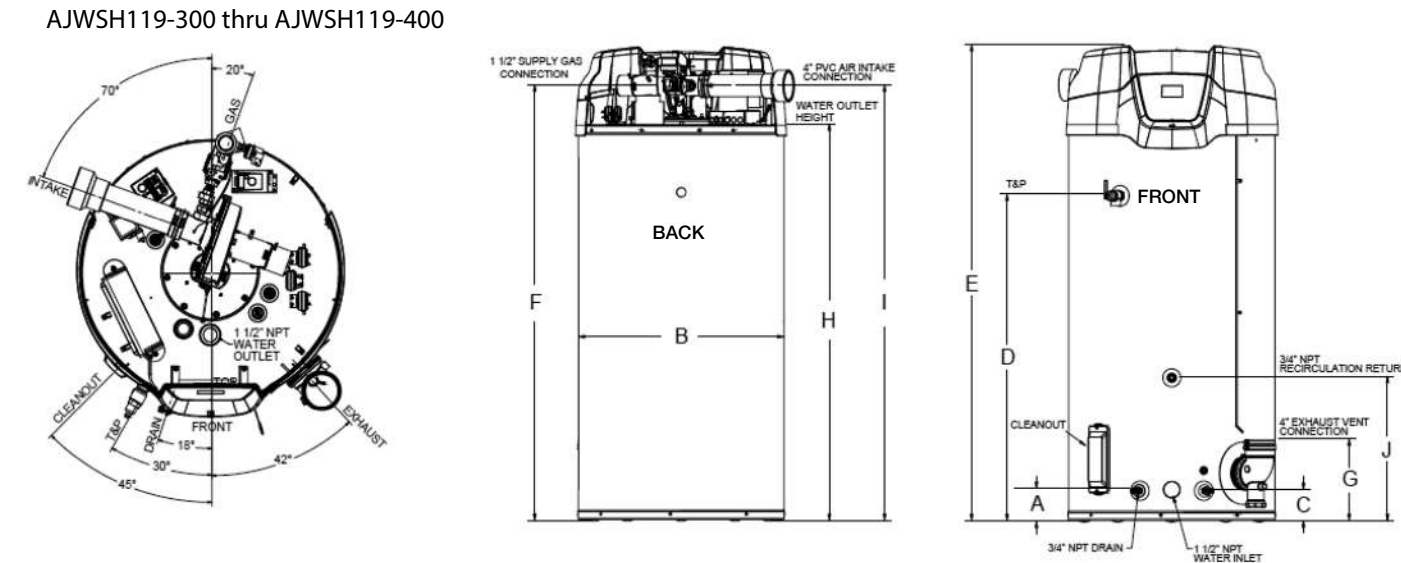

DIMENSIONS													
Model	A	B	C	D	E	F	G	H	I	J	Shipping Weight STD	Shipping Weight ASME	
	IN (CM)	IN (CM)	IN (CM)	IN (CM)	IN (CM)	IN (CM)	IN (CM)	IN (CM)	IN (CM)	IN (CM)	LBS (KG)	LBS (KG)	
(A)JWSH100-150	3 (8)	27 3/4 (71)	6 5/8 (16)	56 3/8 (143)	76 (193)	75 3/4 (192)	11 1/4 (29)	64 (163)	70 (178)	18 1/4 (46)	523 (237)	553 (251)	
(A)JWSH100-199	3 (8)	27 3/4 (71)	6 5/8 (16)	56 3/8 (143)	76 (193)	75 3/4 (192)	11 1/4 (29)	64 (163)	70 (178)	18 1/4 (46)	523 (237)	553 (251)	
(A)JWSH100-250	3 (8)	27 3/4 (71)	6 5/8 (16)	56 3/8 (143)	76 (193)	75 3/4 (192)	11 1/4 (29)	64 (163)	70 (178)	18 1/4 (46)	523 (237)	553 (251)	
AJWSH119-300	4 3/4 (12)	33 3/8 (84)	4 3/4 (12)	52 (132)	75 3/4 (192)	73 3/4 (187)	12 3/4 (32)	63 3/8 (160)	69 1/4 (176)	23 (58)	N/A	855 (387)	
AJWSH119-400	4 3/4 (12)	33 3/8 (84)	4 3/4 (12)	52 (132)	75 3/4 (192)	73 3/4 (187)	12 3/4 (32)	63 3/8 (160)	69 1/4 (176)	23 (58)	N/A	855 (387)	