

Commercial Tankless High Efficiency Condensing Models

High-efficiency gas tankless water heaters with condensing technology that feature 96% thermal efficiency and 185°F maximum temperature setting to lower operating costs and provide the hot water output commercial applications call for.

Features

Designed for Performance

- Condensing technology provides up to 96% thermal efficiency
- 185°F maximum temperature setting
- Primary heat exchanger is constructed of commercial-grade copper that is more resilient to erosion and is 25x better at heat transfer than stainless steel thus stabilizing outgoing water temperatures quicker
- Secondary heat exchanger is made of type 316L stainless steel to protect against corrosion
- Continuous maximum flow rates up to 10.0 GPM
- ENERGY STAR[®] qualified
- Available in natural gas (NG) or propane (LP)
- Includes integrated temperature controller and advanced diagnostics to simplify troubleshooting
- Factory-installed power cord included
- Complies with lead free standards
- Internal freeze protection system
- Easy-Link up to 4 units with no additional parts or accessories needed
- Multi-link up to 20 units with a multi-unit controller (100112691)

Safety Features

- Air-Fuel Ratio (AFR) sensor
- Exhaust & water temperature safety control
- Overheat cut-off fuse

Power Direct Vent Design

- Exhaust, 3" venting up to 70 feet or 4" venting up to 100 feet
- Provides flexible venting with ULC S636, PVC, CPVC, or polypropylene pipe for intake and exhaust (solid core only)
- Category III or IV venting can be used
- Common vent up to 8 units

Accessories

- Pipe Cover
- Neutralizer Kit
- Isolation Valve Kits
- Concentric Termination



CT-199



WARRANTY

6-year limited warranty on heat exchanger in commercial applications

5-year limited warranty on all parts
Consult installation manual for terms and conditions or visit www.johnwoodwaterheaters.com for more information.

SPECIFICATIONS

Model Number	Fuel Type	Gas Consumption Input		Inlet Gas Pressure		Thermal Efficiency	Maximum GPM*	Hot/Cold Connections	Gas Connection	Dimensions IN (CM)			Approx Shipping Weight LB (KG)
		Minimum BTU/h	Maximum BTU/h	Minimum IN. W.C.	Maximum IN. W.C.					Height	Width	Depth	
JCT-199-N	Natural	15,000	199,000	4.0	10.5	96%	10	¾" NPT	¾" NPT	23 ⅝ (60)	17 ¾ (45)	11 ¼ (29)	71 (32)
JCT-199-P	Propane	13,000	199,000	8.0	14.0	96%	10	¾" NPT	¾" NPT	23 ⅝ (60)	17 ¾ (45)	11 ¼ (29)	71 (32)

15-150 psi Water Pressure. 40 psi or above is recommended for maximum flow.

*Current numbers based on factory testing; 0.4 GPM required for continuous fire after initial ignition.

Models are certified from sea level to 10,100 ft. elevations.

The manufacturer reserves the right to discontinue, or change at any time, specifications or designs without notice and without incurring obligation.

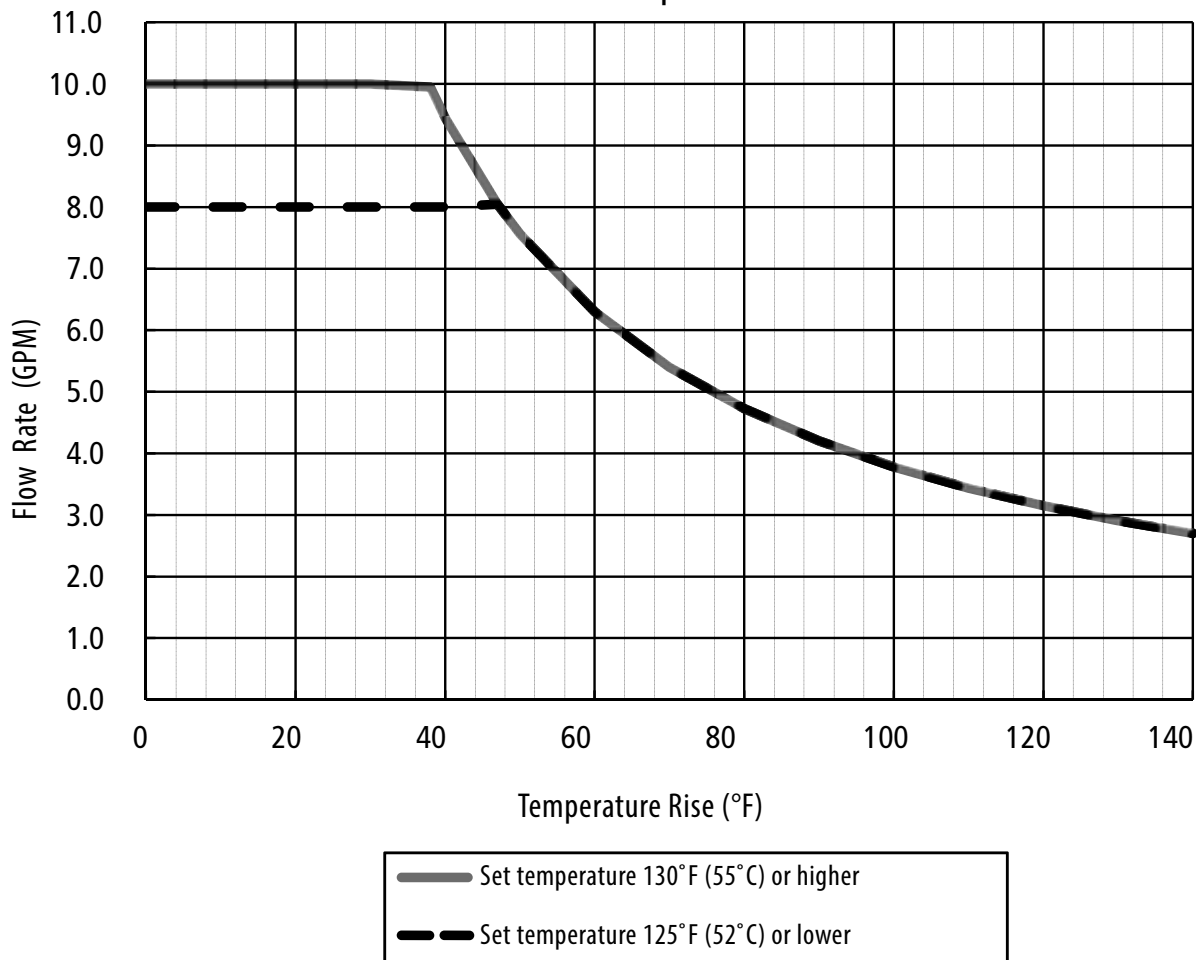
CT-199 MODEL
Flow Rate vs Temperature Rise

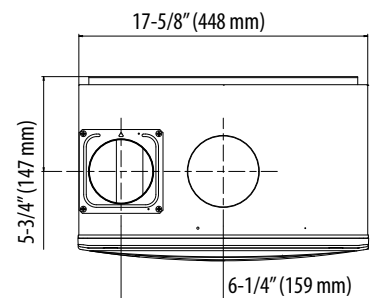
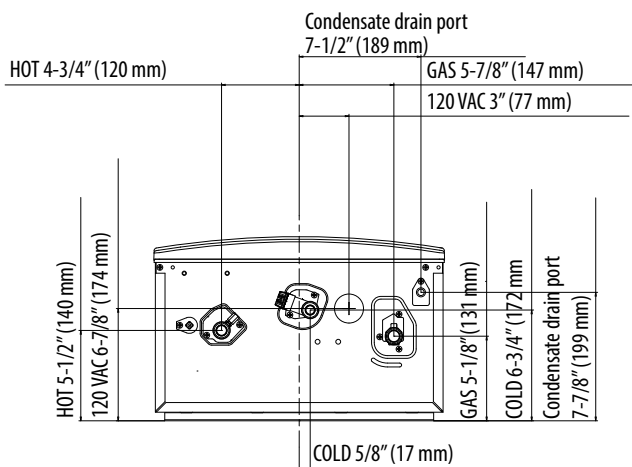
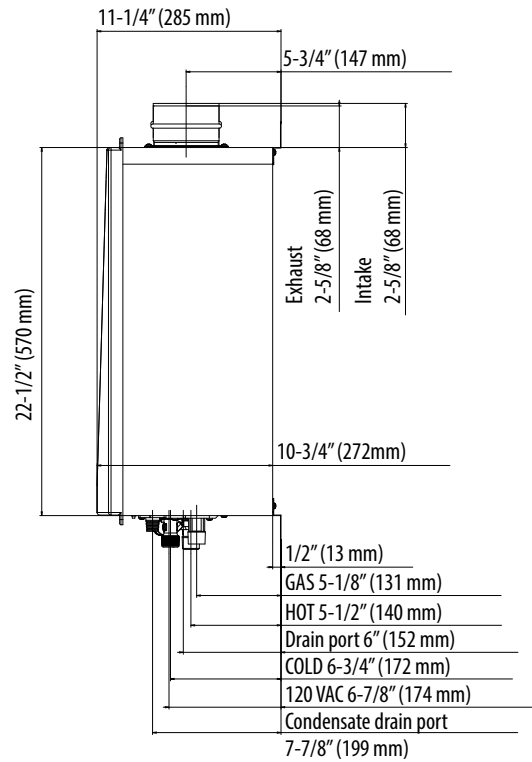
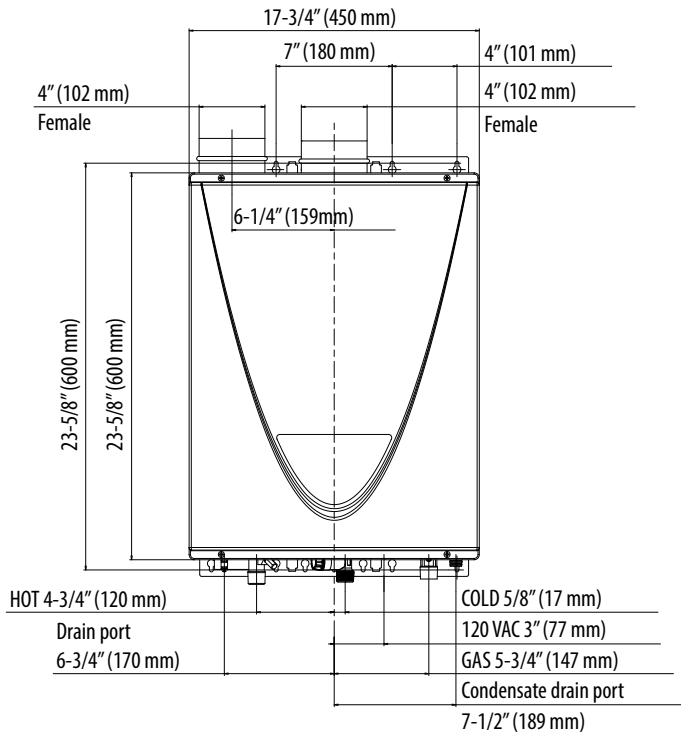



OPTIONAL ACCESSORIES	
Part Number	Description
100112163	Concentric Termination Kit
100112159	Condensate Neutralizer Kit
100112691	Multi-Unit Controller
100112156	Isolation Valve Kit (with Pressure Relief Valve)
100112718	Pipe Cover
100113154	Product Preservers® Anti-Scale System
100113130	Non-return Valve for Common Vent Systems

TANKLESS CONDENSING HIGH EFFICIENCY COMMERCIAL GAS SPECIFICATIONS

The fully modulating, on-demand, condensing gas fired commercial tankless water heater(s) shall be John Wood model JCT-199, having a maximum input rating of 199,000 BTU/h and available in NG or LP. The heater shall have ¾ in. male NPT water and gas connections. The inlet gas supply pressures shall be 4.0 in. W.C. (min.) up to 10.5 in. W.C. (max.) for NG and 8.0 in. W.C. (min.) up to 14 in. W.C. (max.) for LP. The heater(s) shall incorporate an integrated temperature controller that will provide diagnostic information, fault history, and heater set temperature. The heater(s) shall operate using 120 V / 60 Hz power source. The heater(s) will incorporate a factory installed power cord.

The heater(s) exhaust shall be vented with 3" or 4" diameter ULC S636 approved schedule 40 PVC, CPVC, polypropylene or Category III/ IV vent pipe with a length not to exceed 70 ft. (equivalent) for 3" vent or 100 ft. (equivalent) for 4" vent, terminating horizontally or vertically. The intake pipe may use material such as PVC, ABS, polypropylene, aluminum, or Category III/ IV pipe and cannot exceed 70 ft. (equivalent) for 3" vent or 100 ft. (equivalent) for 4" vent.

The water heater(s) shall use a commercial-grade copper, fin tube primary heat exchanger with quick release brass or bronze waterways. The secondary heat exchanger shall be constructed from stainless steel 316L. The heater(s) shall be controlled by an on-board solid-state printed circuit board which uses the following factory installed components: thermistors to monitor water temperature and exhaust temperature; a flow sensor to measure flow rate; a flame sensor to monitor combustion; an Air-Fuel Ratio Rod to measure and adjust air input in order to maintain optimal combustion efficiency. The heater also consists of in-line fusing and surge absorbers for electrical surge protection, an electronic spark igniter, aluminized stainless steel burners, hi-limit temperature switches to monitor water and exhaust temperatures, modulating gas valve, dual freeze protection that will automatically fire the heater and use heating blocks to protect the heat exchanger, and an overheat cutoff fuse.

The heater(s) can manifold to Easy-Link up to 4 heaters to provide additional capacity. The Easy-Link controls shall be built onto the on-board solidstate printed circuit board and does not require external controls. The linking control wire shall be supplied with the heater. The heater(s) can use a Multi-Unit controller, 100112691, to manifold 5-20 heaters. The Easy-Link and Multi-Unit Controller shall modulate the system for the most efficient performance. The Easy-Link and Multi-Unit Controller shall rotate the priority heater every 12 hours of operation time or 100 starts for balanced duty/cycle operation.

The heater(s) shall be CSA approved for sale in the United States and Canada, ENERGY STAR® qualified with a thermal efficiency of 96%, meets the energy efficiency requirements of NRCan and current edition of ASHRAE 90.1, and shall be certified to NSF 5 Standards.