

OIL FIRED WATER HEATER

**INSTALLATION INSTRUCTIONS
FOR
THROUGH-THE-WALL
VENTING COMPONENTS**

These instructions apply for the installation of the venting duct including the outdoor vent terminal for the JW6 F307V “Through-The-Wall” Vented Oil Fired Water Heater.

The general installation instructions in the manual supplied with this Water Heaters apply, with the **exception** of the applicable section under “**Venting**” and the method for “**Air Adjustment**”.

The instructions contained herein must be followed in its place.

Refer to the following diagram for the identification of the vent components:
(Figure 1)

NOTE: THE VENT COMPONENTS MUST BE USED AS SUPPLIED WITHOUT ANY ALTERATION.

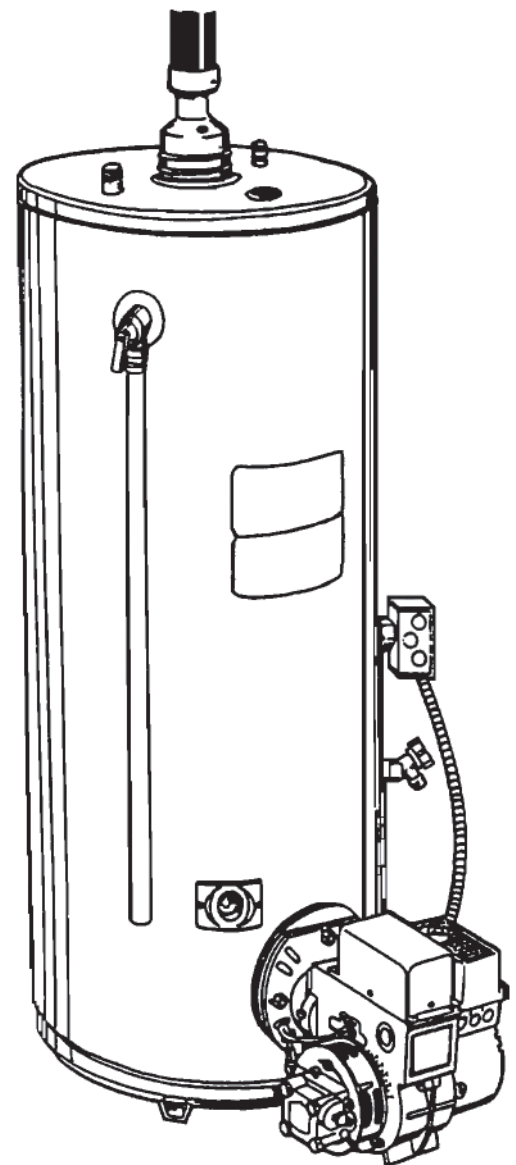

TABLE OF CONTENTS

I) LOCATION.....	3
II) DETAILED INSTRUCTIONS.....	4
III) INITIAL START-UP.....	7
IV) TEST FOR LEAKS.....	7
V) ANNUAL INSPECTION.....	7
VI) REPLACEMENT PARTS.....	7

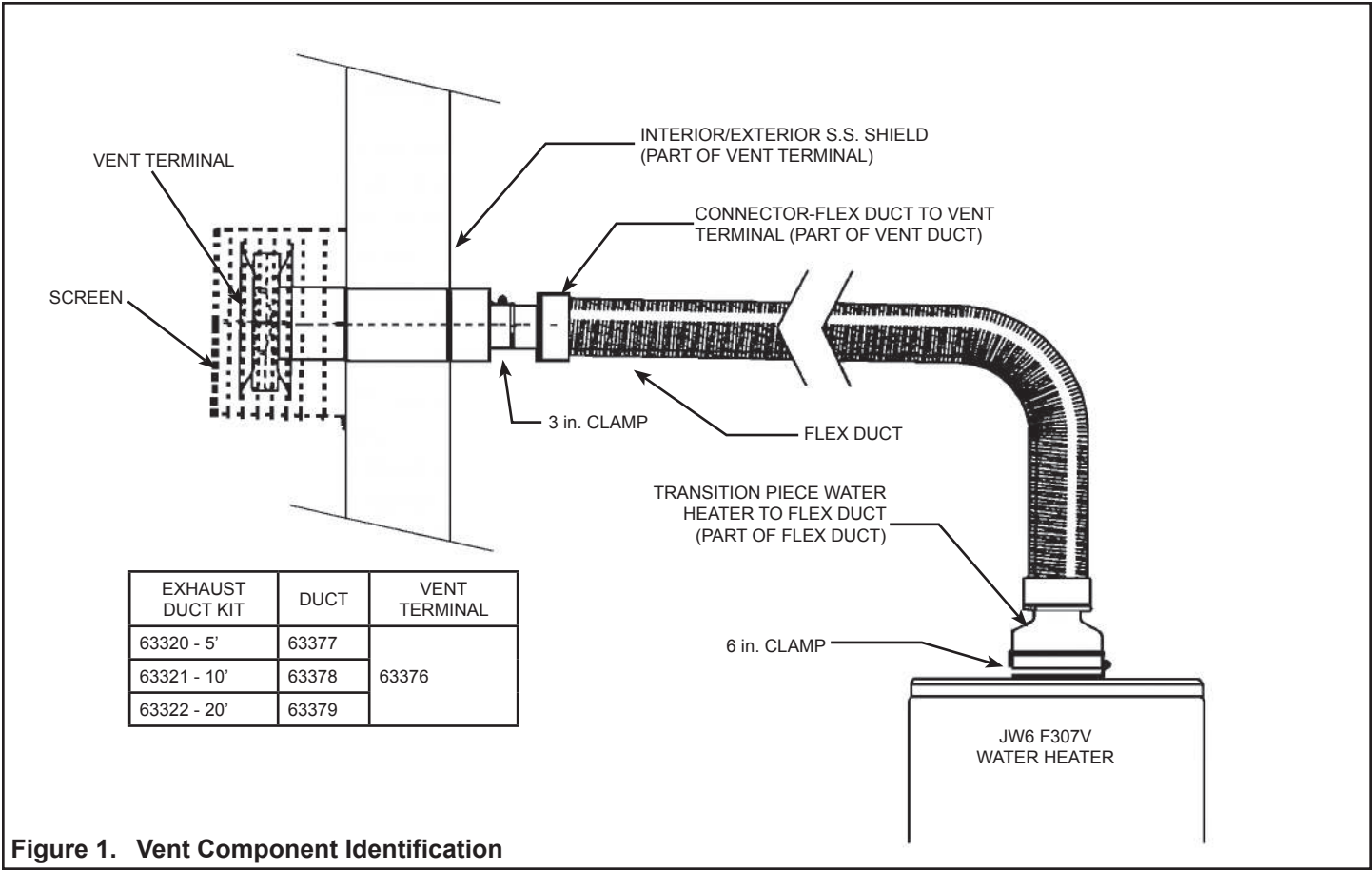

Figure 1. Vent Component Identification

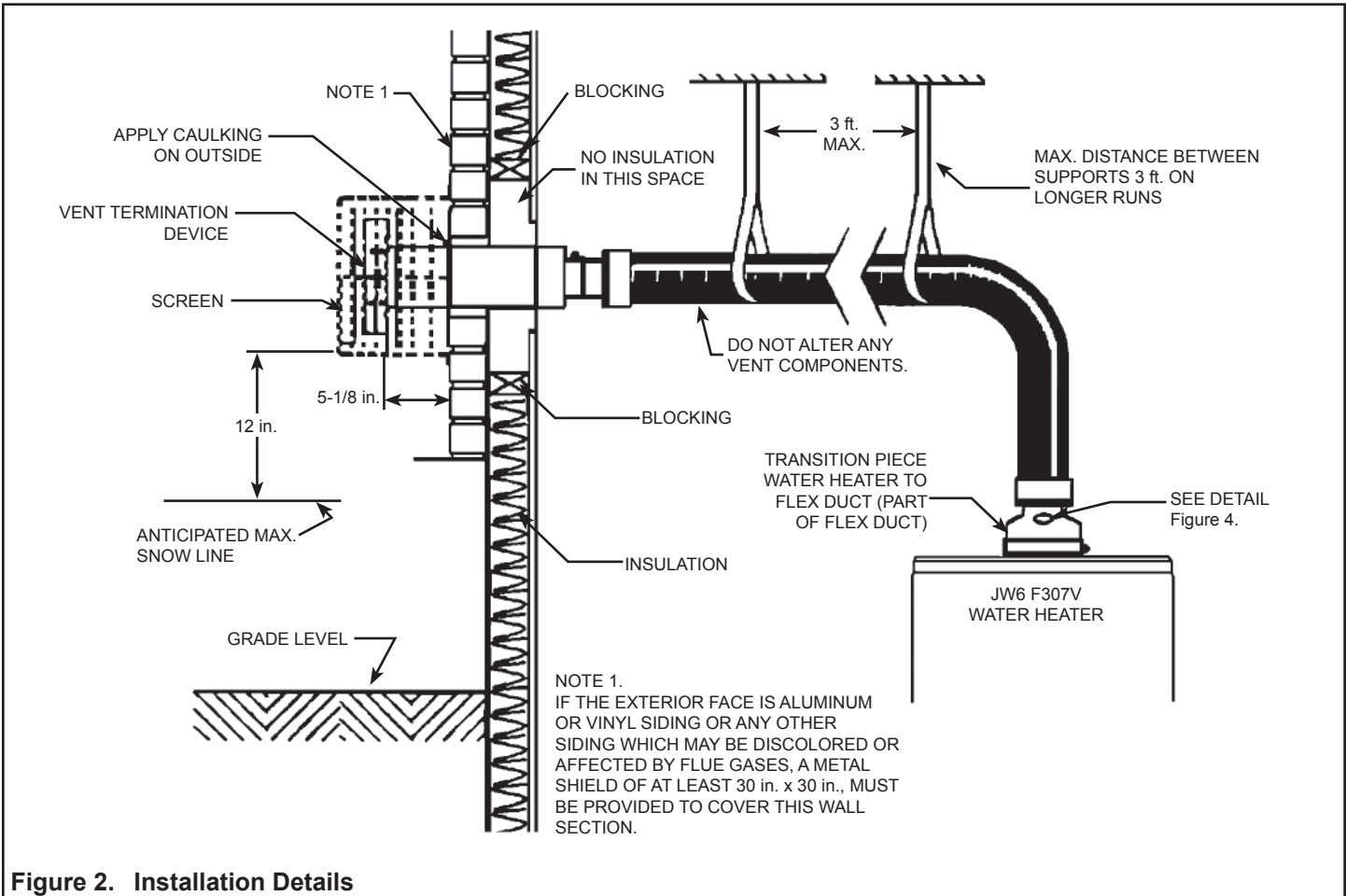

Figure 2. Installation Details

I) LOCATION

Locate the water heater as close as possible to an exterior wall to minimize the length of flex duct required. However, the minimum length available is 5 ft. and under no circumstances must any component be altered. Consider the direction of predominant winds and the possible snow accumulation against that side of the building (see Figure 2).

The vent terminal must have sufficient clearance from ground level so that it will not be buried in snow. The location of the vent terminal must also meet the regulations of the “**Installation Code for Oil Burning Equipment**” **NFPA 31** (also see Figure 3).

1. The vent terminal shall terminate at least 3 ft. above any air inlet to the structure that is within 10 ft. of the termination point.
2. The sub vent terminal shall terminate at least 4 ft. below, 4 ft. horizontally from, or 1 ft. above any door, window, or gravity air inlet of the structure and also shall terminate at least 1 ft. above grade.
3. The sub vent terminal shall terminate at least 1 ft. from the soffit of the roof of the structure and at least 3 ft. from an inside corner of an L-shaped structure.
4. The sub vent terminal shall not be less than 7 ft. above grade when located adjacent to public walkways.
5. The sub vent terminal shall terminate at least 5 ft. from the vent outlet of a liquid fuel supply tank.

Note: Outside combustion air kits which are designed for use with burners that allow for ducting outside combustion air directly to the burner are available (see Table 1).

Kit	Burner
CAS-28	Becket-AF/AFG
CAS-2C	Carlin-EZ-1/CRD/FRD

Table 1.

Important: All installation and service of these kits must be performed by a qualified installation and service agency.

II) DETAILED INSTRUCTIONS

1. Drill or cut an opening through the exterior wall and fasten the vent terminal as shown in Figure 3.
2. Push the vent terminal from the outside through the wall and fasten the outer shield with the 4 screws provided.
3. Seal around the perimeter of the outer shield with caulking material which has a temperature rating of at least 167°F.
Note: A silicone type of caulking is recommended.
4. From inside the home, place the second shield around the tube of the vent terminal and fasten it with the 4 screws provided. Tighten the gear clamp securely. This completes the installation of the vent terminal.
5. Maintain clearances to combustible material (2" x 4" or 2" x 6" framing) as per Figure 3. **Note:** If the flex duct is to be located between joists, the spacers provided must be used to maintain clearances to combustible material.
6. Inside the home, attach the smaller end of the flex duct to the vent terminal. Use the 3 in. band clamp with the gasket attached (inside the clamp). The edges of the band clamp must engage both beads (the one on the vent terminal and on the flex duct) so that the gasket straddles the joint.
7. Run the flex duct to the water heater. All bends should be as generous as possible. Avoid sharp bends. Do not kink the duct.
8. Support longer horizontal runs. Maximum spacing must not exceed 3 ft. (see Figure 2).

If the flex duct is run between ceiling joists, the spacers as provided must be used. See the details illustrated in Figure 4.

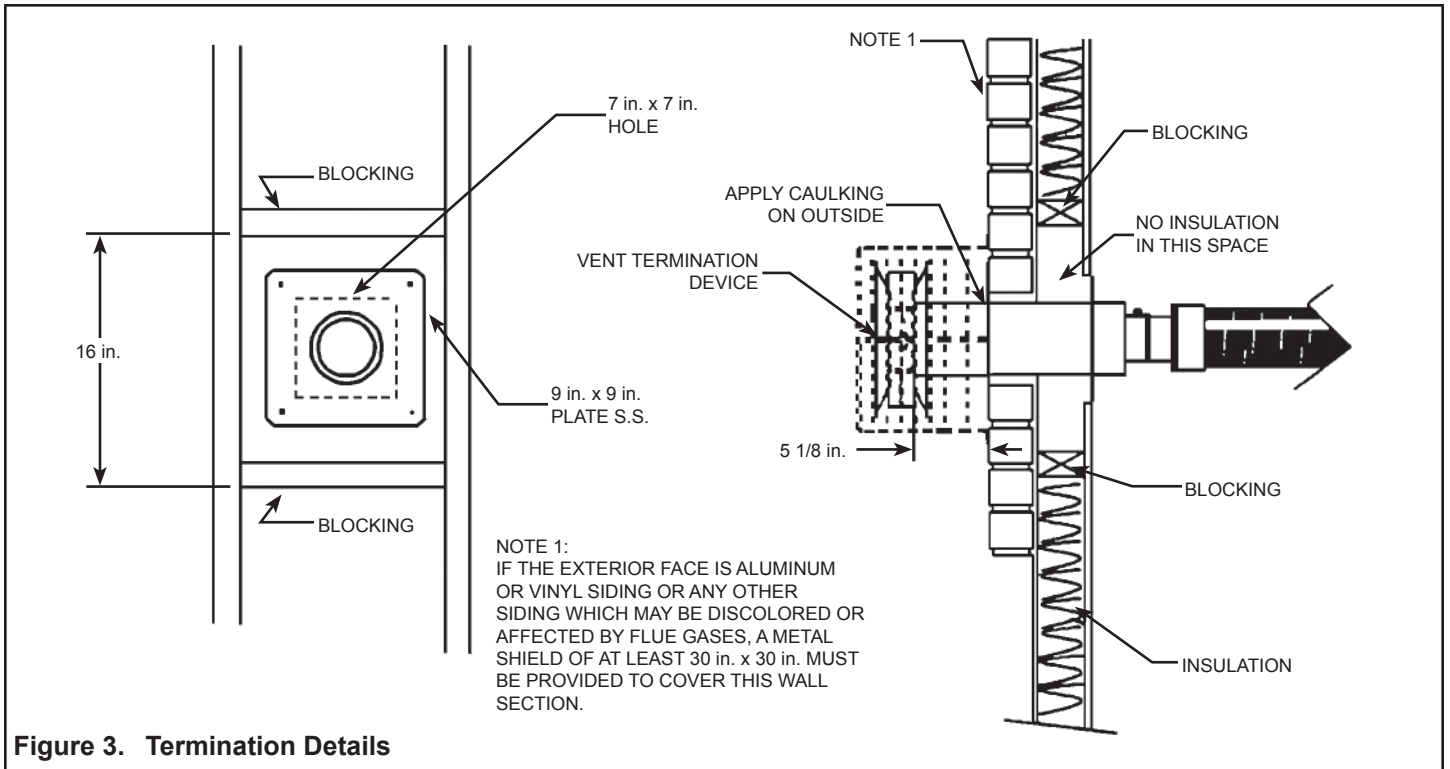

Figure 3. Termination Details

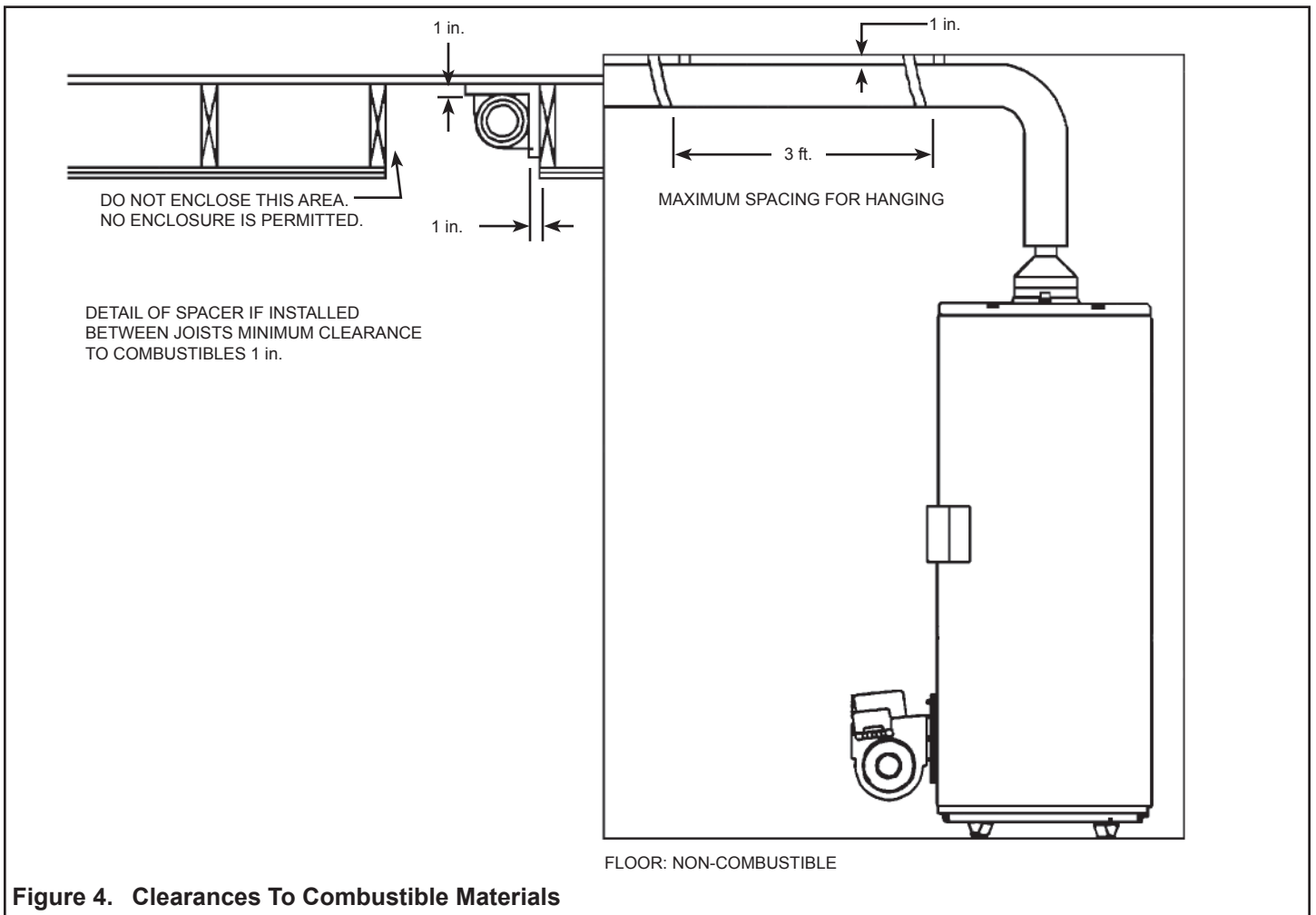

Figure 4. Clearances To Combustible Materials

To attach the flex duct to the water heater

(see Figure 5).

1. Place the band clamp around the transition piece (16 in. diameter) of the flex duct.
2. Slide the transition piece over the water heater flue outlet.
3. Leave a gap of approximately 5/8 in. to 3/4 in. between the edge of the transition piece and the water heater casing top.
4. Slide the band clamp down so that the gasket straddles the edge of the transition piece. The crimp of the clamp must engage the bead on the transition piece.
5. Tighten the gear clamp.

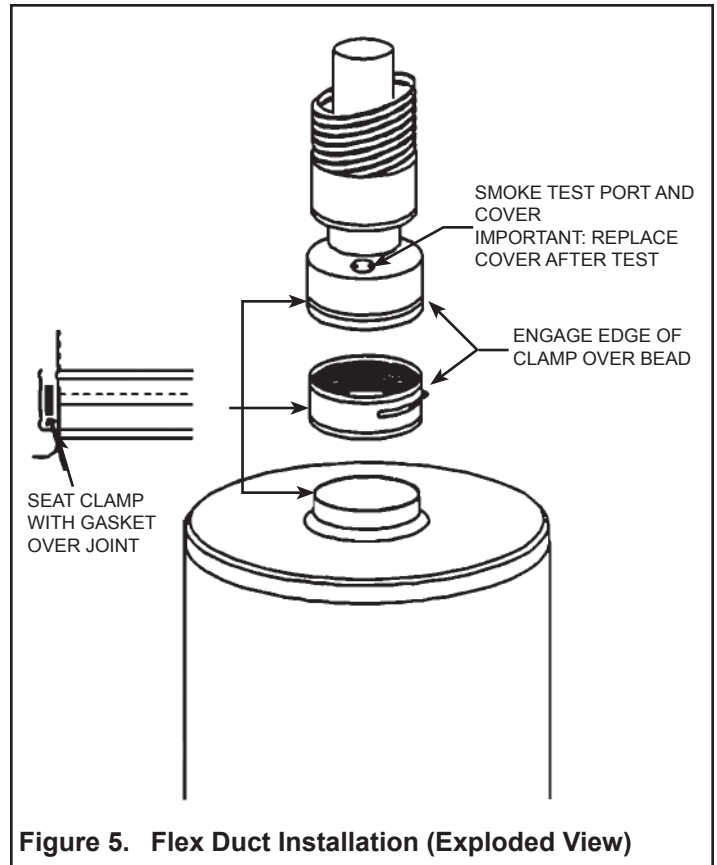

Figure 5. Flex Duct Installation (Exploded View)

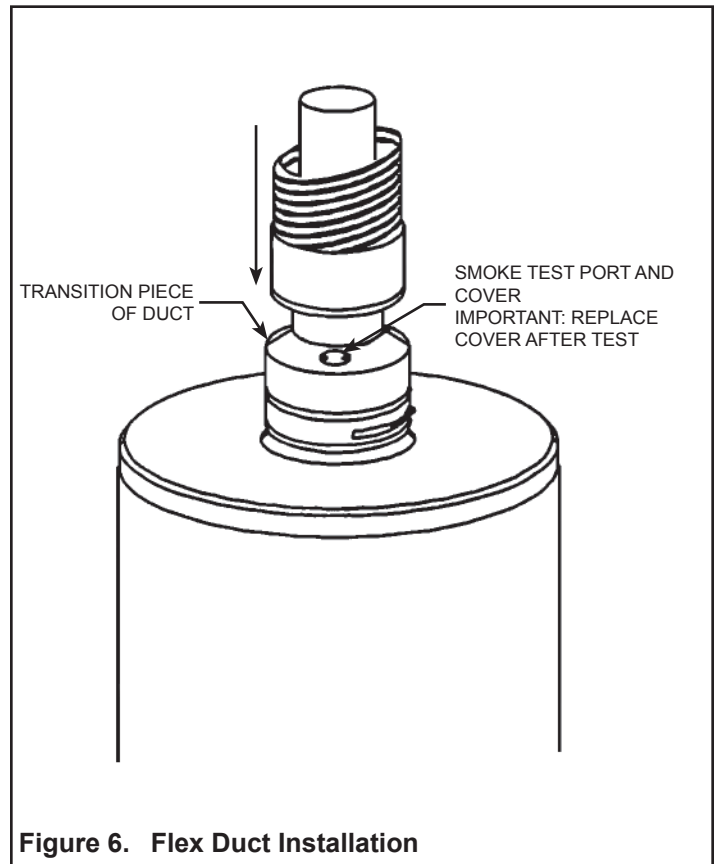

Figure 6. Flex Duct Installation

III) INITIAL START-UP

The burner is equipped with pre-purge and post-purge control. The pre-purge is set for a timing of 15 seconds, +5 seconds, -0 seconds. The post-purge is set for 3 minutes.

After the burner has started to fire, allow the heater to operate for 10 to 15 minutes (from a cold start). Take a smoke reading. An opening for smoke readings is provided in the transition piece of the duct (Figure 6).

The smoke must be adjusted to a maximum of #1 smoke. With an adjustment of #1 smoke, the overfire pressure should be between 0.20 in. w.c. and 0.25 in. w.c. (0.049 to 0.062 kPa). Take care to replace the sealing screw in the overfire pressure test port to prevent flue gas from escaping from the combustion zone into the home (Figure 7).

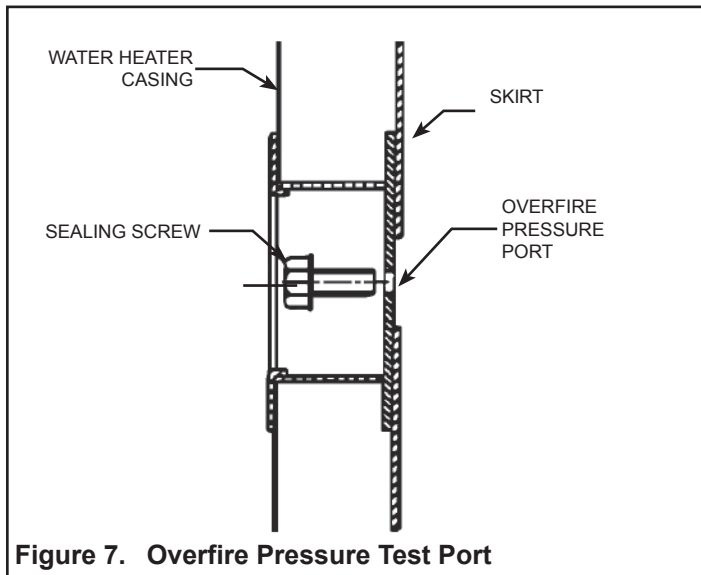

Figure 7. Overfire Pressure Test Port

IV) TEST FOR LEAKS

With the heater still running, test around the band clamp at the flue connection of the heater for leaks. Use a smoke pencil or similar device. Make sure the clamp is tight and no flue gases escape at this point.

Repeat the procedure at the connection between the flex duct and the vent terminal (inside the house). If leakage is detected, it may be due to misplaced clamps over the joint. Please repair all leaks.

Note: The gasketing material is a special high temperature Teflon. DO NOT SUBSTITUTE. If more gasketing is required for repair it can be obtained where you purchased this heater.

IF YOU CAN SMELL FLUE GASES IN THE HOME, IT IS A SIGN OF LEAKAGE SOMEWHERE IN THE FLUE SYSTEM. CHECK FOR LEAKAGE AT ALL JOINTS OF THE FLEX DUCT (AT THE HEATER CONNECTION AND THE VENT TERMINAL). MAKE SURE THE SMOKE SAMPLING PORT IS SEALED WITH THE COVER AND GASKET (see Figure 6).

V) ANNUAL INSPECTION

Once a year inspect all vent joints for leakage as described in the section under "Initial Setup". Inspect the outside vent terminal and remove any debris which may have accumulated.

Perform a combustion test and overfire test as described in the same section.

Repair all leaks as required and make the necessary burner adjustments to obtain the prescribed smoke readings at the maximum overfire pressure.

Replace leaking band clamps with new ones as required.

VI) REPLACEMENT PARTS

Part No.	Description
63376	Termination Device
63377	Flex Duct and Transition 5 ft. long
63378	Flex Duct and Transition 10 ft. long
63379	Flex Duct and Transition 20 ft. long
63386	Termination Screen
63400	Clamp 3 in. complete with Gasket
63401	Clamp 6 in. complete with Gasket

Table 2.

This page intentionally left blank. May be used for notes or to record other installation information.