



## The Quiet Tradition Continues...

With an advanced line of sealed combustion  
power direct vented water heaters.

The Power Direct Vent™ (PDV) is designed with a sealed combustion chamber, ultra quiet blower and state-of-the-art gas control for highly accurate and reliable temperature control.

Perfect for both residential new home construction and replacement water heater applications; the Power Direct Vent™ will provide the ultimate solution for your hot water needs.



### WATER HEATER FEATURES

#### Energy Savings

- Exceeds energy efficiency standards
- No heated indoor air used for combustion

#### High Quality Features

- 40/40 and 50/40 units are ready for ENERGY STAR® qualification
- Exclusive patented TankSaver® design to prolong tank life
- Low profile design is ideal for replacement applications
- Conveniently located T&P and drain valve for serviceability

#### Industry Leading, Ultra Quiet Blower

- Continues the GSW tradition of quiet power vent water heaters

#### Sealed Combustion Chamber Design

- Prevents accidental ignition of flammable vapours
- Enhances air quality as no indoor air is required for combustion
- Great for tight space installations

#### Flexible Venting Configurations

- Can be vented with PVC or CPVC up to 60 equivalent feet for the 50/65 and 50 equivalent feet for the 40/40 and 50/40, horizontally through the wall or vertically through the roof (see installation manual for full details)
- Auto-reset temperature switch monitors vent temperature



An advanced line of sealed combustion power direct vented water heaters.

**CAPACITY & DIMENSIONS**

Model	Capacity USG (Litres)	BTU Input	Recovery @ 100°F/55°C Rise USG (Litres)	Energy Factor	Height to Top of Blower A in. (cm)	Height to Top of Tank B in. (cm)	Diameter C in. (cm)	Overall D in. (cm)	Depth Vent in. (cm)	Approximate Shipping Weight lb. (kg)
<b>NATURAL GAS - 8 and 2 year warranty</b>										
JW4040SN-PDV-ES	40 (151)	40,000	33.93 (128.44)	0.67	59.5 (151.1)	51 (130)	22.6 (57)	25.38 (64.46)	2 (5.1)	162 (73)
JW5040SN-PDV-ES	50 (189)	40,000	33.93 (128.44)	0.67	68.5 (174.0)	60 (152)	22.6 (57)	25.38 (64.46)	2 (5.1)	182 (82)
JW5065SN-PDV-02	50 (189)	65,000	60 (227)	0.60	61.7 (157)	52 (132)	22.6 (57)	31 (79)	3 (7.6)	190 (86)
JW5065SN-PDV-04	50 (189)	58,500	54 (204)	0.60	61.7 (157)	52 (132)	22.6 (57)	31 (79)	3 (7.6)	190 (86)
<b>PROPANE - 6 and 1 year warranty</b>										
G4040SP-PDV-ES*	40 (151)	40,000	33.93 (128.44)	0.67	59.5 (151.1)	51 (130)	22.25 (56.56)	25.38 (64.46)	2 (5.1)	162 (73)
G5040SP-PDV-ES*	50 (189)	40,000	33.93 (128.44)	0.67	68.5 (174.0)	60 (152)	22.25 (56.56)	25.38 (64.46)	2 (5.1)	182 (82)

High altitude models are de-rated by 10% as per CSA.

\* Propane models will be GSW branded and carry a 6-year limited tank warranty.

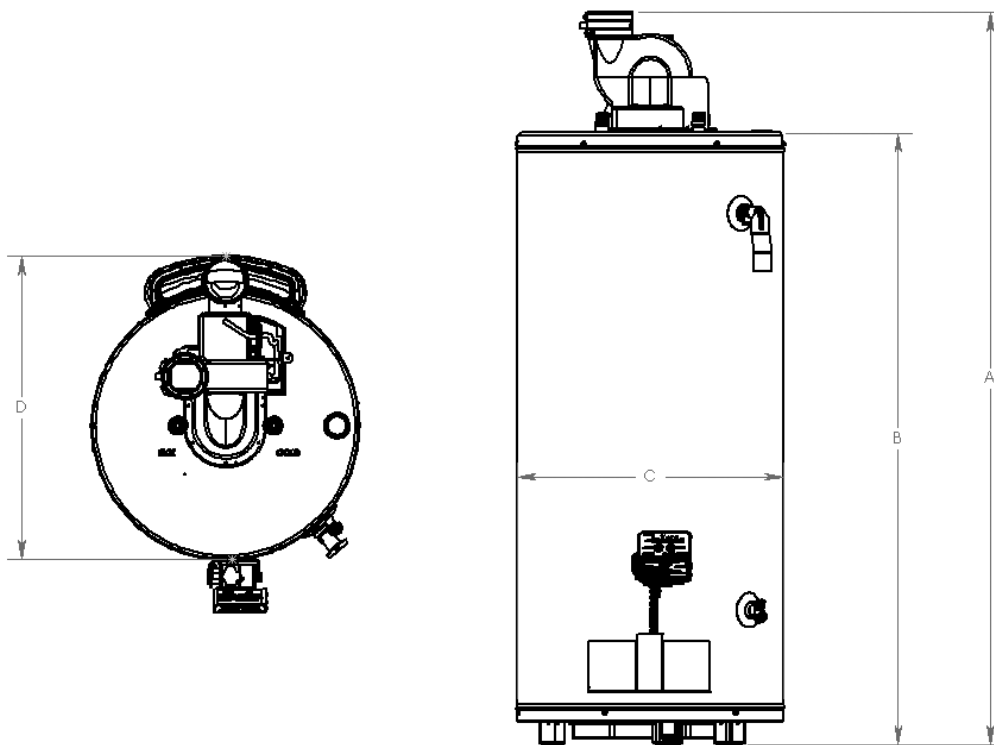

Contact GSW Water Heating  
[www.johnwoodwaterheaters.com](http://www.johnwoodwaterheaters.com)

**GSW Warranty:**

All GSW and John Wood® Water Heaters will be replaced free of charge in the case of tank leakage within the stated warranty period from the date of installation in domestic applications, and one year in commercial applications. All parts supplied are warranted for one year. Warranty does not include labour. Consult owner's manual for complete details.